

FT
599.
07
501

SCIENCE AT WORK

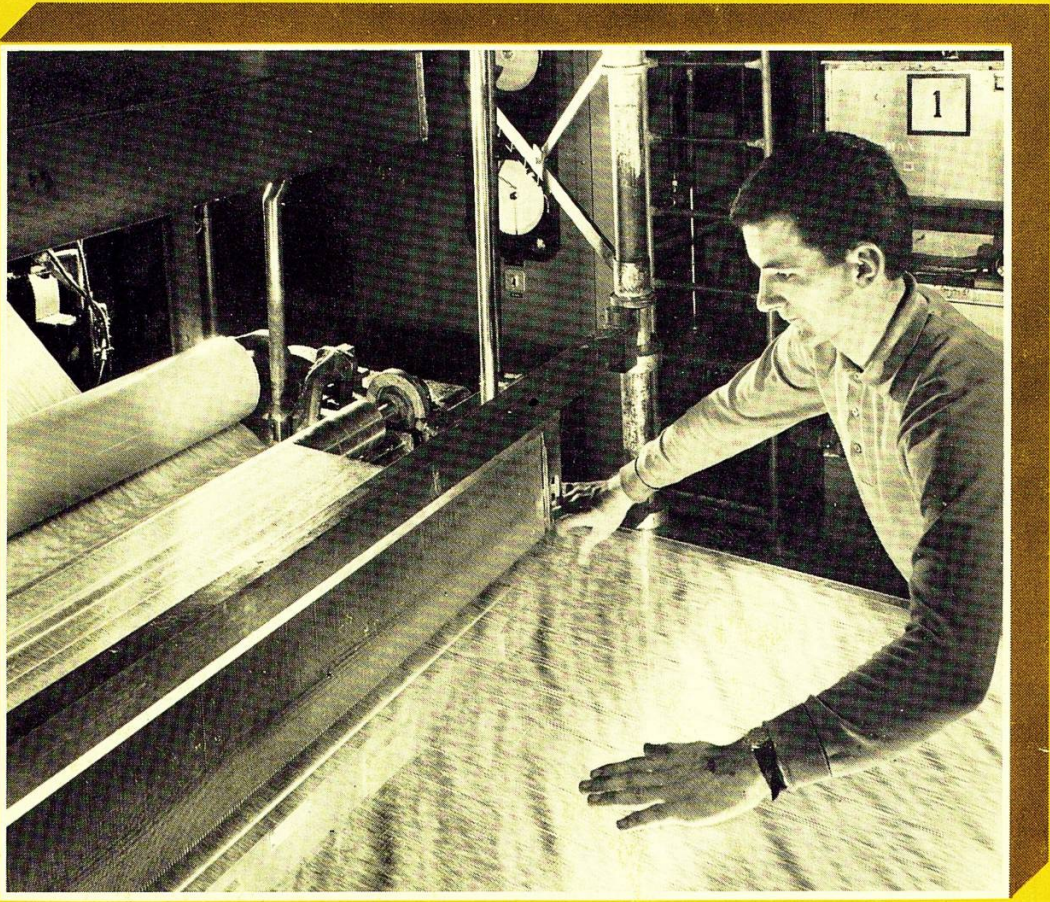

Fibres and Fabrics

A 507.12 TAY

SCIENCE AT WORK

Project Director
John Taylor

Editorial Team
Jackie Hardie
Peter Llewellyn
Colum Quinn
Keith Roberts

Language Consultant
Grahame Mitchell

This book from an original manuscript by
Sister Andrew, M. Morgan and W.J. Hoare.

Contents

| | | |
|----|------------------------|----|
| 1 | Examining fibres | 1 |
| 2 | Burning fibres | 4 |
| 3 | Paper | 8 |
| 4 | Making fibres | 11 |
| 5 | The strength of fibres | 14 |
| 6 | The wear of fabrics | 18 |
| 7 | Fabrics as insulators | 20 |
| 8 | Shrinkage | 23 |
| 9 | Detergents | 26 |
| 10 | Fabric brighteners | 30 |

Acknowledgements—inside back cover

This book is to be returned on or before
the last date stamped below.

| |
|--------------------------|
| 12 DEC 1986 |
| 10 DEC 1982 CANCELLED |
| 25 JUN 1987 |

© 1979 by Addison-Wesley Publishers Limited
West End House, 11 Hills Place, London W1R 2LR
Philippines copyright 1979 by Addison-Wesley
Publishers Limited.

All rights reserved. No part of this publication may be
reproduced, stored in a retrieval system, or transmitted in any
form or by any means, electronic, mechanical, photocopying,
recording or otherwise, without prior written permission of
the publisher.

ISBN 0 201 14000 4

Designed, set and illustrated by Parkway Group and
printed in Great Britain by Pindar Print, Scarborough

ABCDEF 79

12433503



TELEPEN



| |
|---|
| LIBRARY BULMERSHE COLLEGE OF HIGHER EDUCATION READING |
| ACCESS No: 124335 |
| CLASS No: FT 99-07 |

JAL

Examining fibres

Looking at fibres

Apparatus

- ★ labelled samples of fabrics
- ★ 2 slides
- ★ microscope
- ★ lamp
- ★ dropper
- ★ tweezers
- ★ beaker of water

You are going to look at different fibres.

Q1 Copy this table.

| Name of fabric | Drawing of fibre |
|----------------|------------------|
| | |

A Work with one of the fabrics. Pull out a fibre using tweezers.

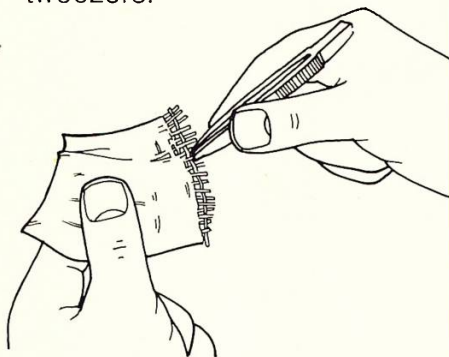

B Put the fibre onto a microscope slide. Put a **drop** of water on top of the fibre.

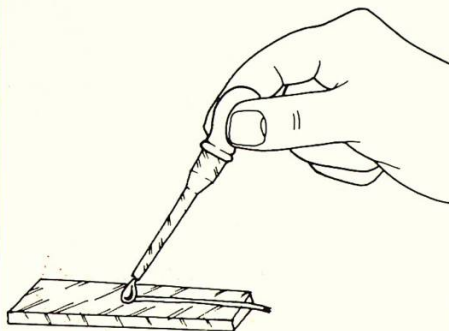

C Cover the first slide with a second slide.

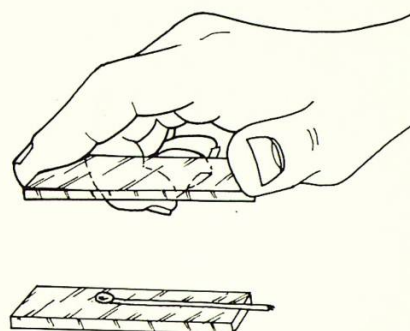

D Put the slides under a microscope. Look at the middle and end of the fibre. (Use low magnification.)

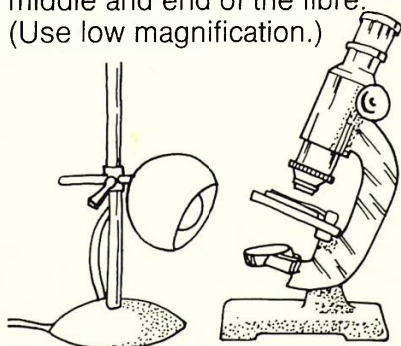

E Write the name of the fabric in your table. Then draw the fibre.

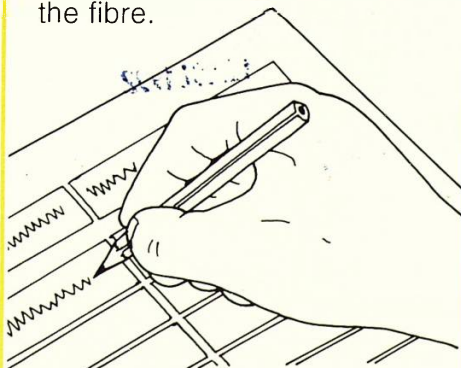

F Repeat steps A to E for the other fabrics.

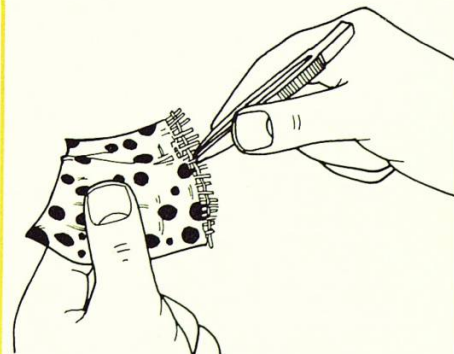

Q2 Which fibres were twisted?

Q4 Which fibres were made of smaller fibres?

Q3 Which fibres were covered in scales?



N23574

Examining fibres

Identifying fibres

Apparatus

- ★ 2 numbered fabrics
- ★ 2 slides
- ★ microscope
- ★ lamp
- ★ dropper
- ★ tweezers
- ★ beaker of water
- ★ your table from page 1

You are going to identify the two numbered fabrics.

A Work with fabric 1. Pull out a fibre using tweezers.

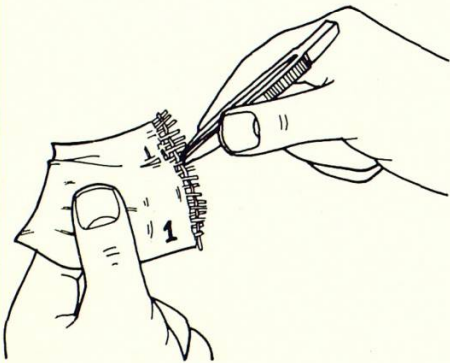

B Put the fibre onto a microscope slide. Put a **drop** of water on top of the fibre.

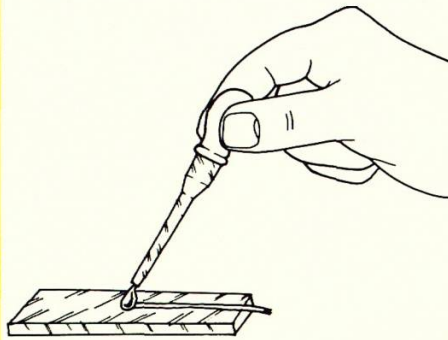

C Cover the first slide with a second slide.

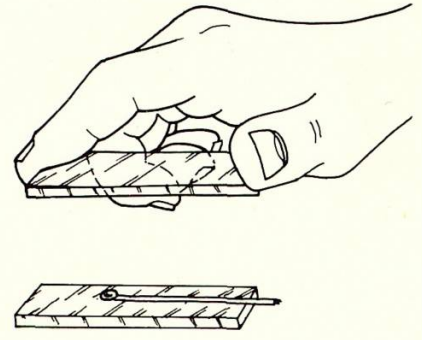

D Put the slides under a microscope. Look at the middle and end of the fibre under a microscope. (Use low magnification.)

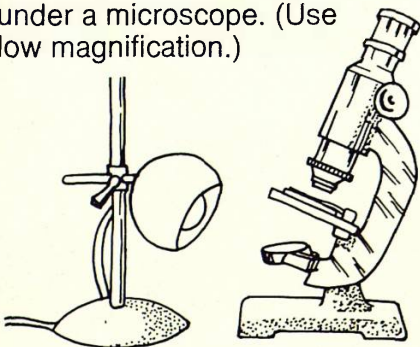

E Compare what you see with your table from the last experiment. Identify the fabric. Then repeat with fabric 2.

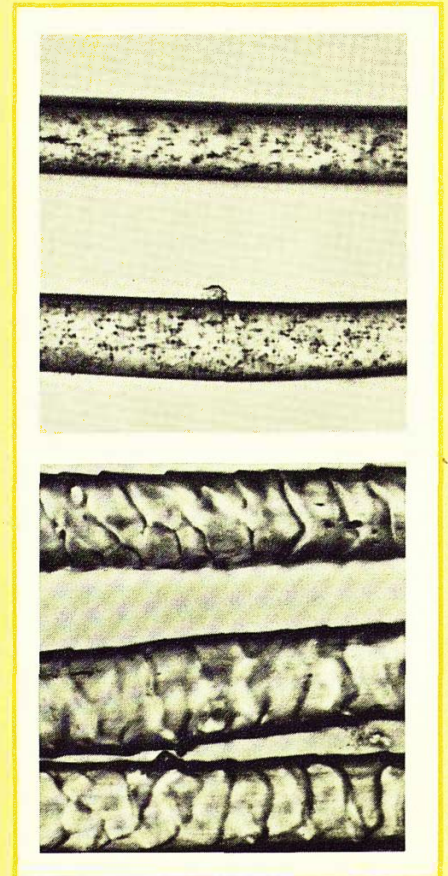
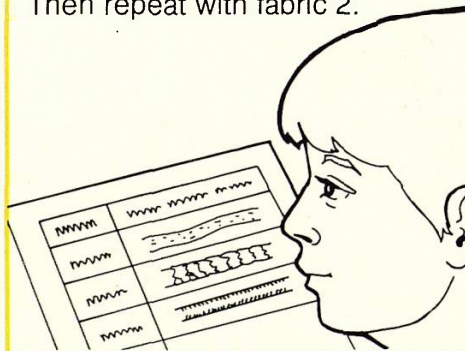

Q5 What is fabric 1?

Q6 What is fabric 2?

Q7 What fabrics do these fibres come from? ➔

Information: Cotton

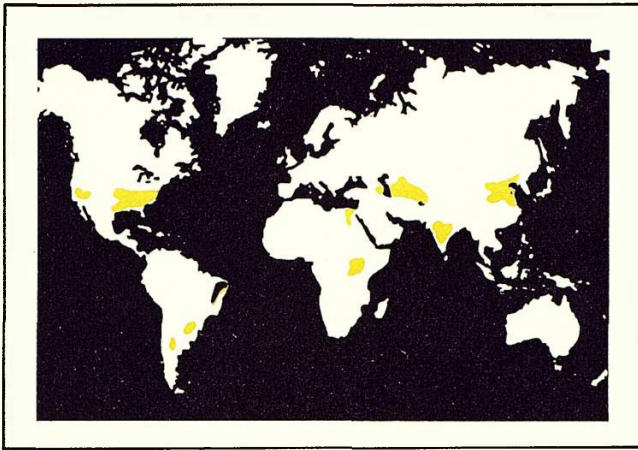

Cotton fibres come from a bushy plant which grows in tropical countries. Cotton fabric is made in the following way.



When a cotton flower (left) dies it leaves behind seed pods called **bolls**. The bolls ripen and burst open, leaving fluffy cotton fibres (right). These are collected.

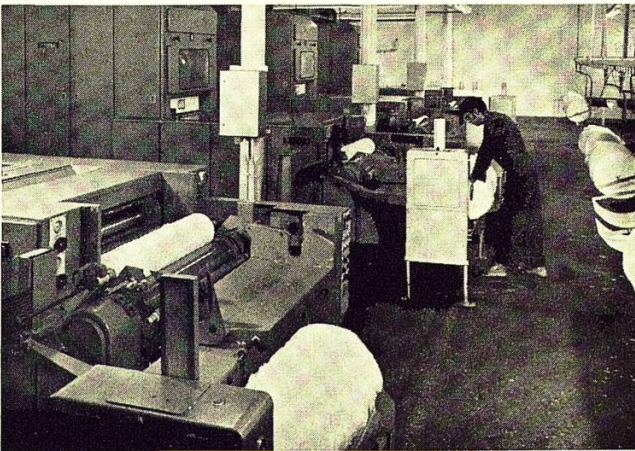

In cotton mills in countries like England and India, the picked cotton is torn apart by machines. This makes **lap**, which is like cotton wool.

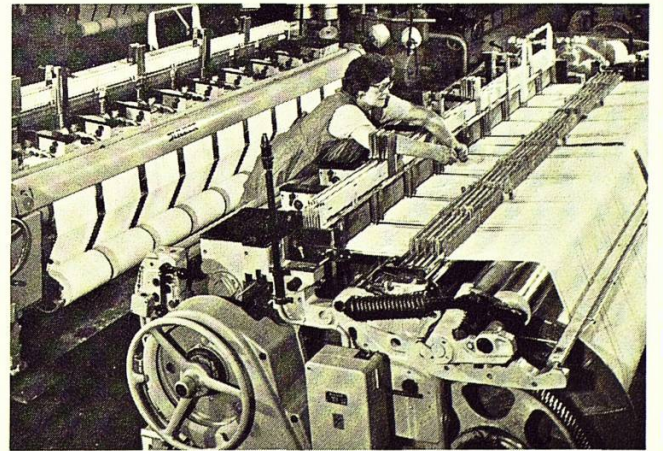

A machine pulls the fibres of lap into thick ropes or **slivers**. These are combed to remove any short fibres. The slivers are then drawn out and spun into yarn. This is woven into fabric, like the towels in the photograph.

Q8 What is a cotton boll?

Q9 Why is cotton combed after it has been made into slivers?

Q10 Name three countries where cotton is grown.

Q11 Name some of your clothes that are made of cotton.

2 Burning fabrics

Identifying fabrics by burning

Apparatus

- ★tongs ★gauze ★scissors ★tripod ★tin lid ★hand lens
- ★Bunsen burner ★heatproof mat ★numbered samples of fabrics

You are going to identify fabrics by burning them.

Q1 Copy this table.

| Fabric name | Did it melt on the lid? | Did it burn-fast, slowly or not at all? | Was the burned fabric light, dark or black? | Did the burned fabric bend or snap? | Fabric number |
|-------------|-------------------------|---|---|-------------------------------------|---------------|
| | | | | | |

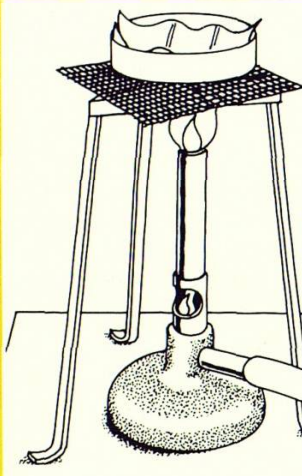

A Cut fabric 1 in half. Put one half on a tin lid. Heat with a low flame. Record the result in your table.

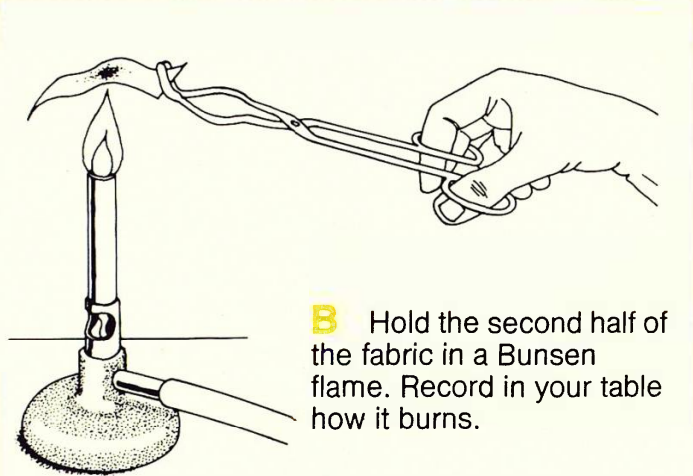

B Hold the second half of the fabric in a Bunsen flame. Record in your table how it burns.

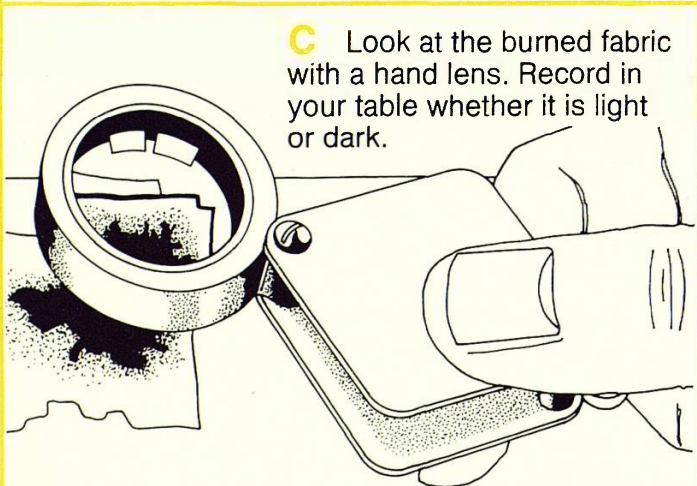

C Look at the burned fabric with a hand lens. Record in your table whether it is light or dark.

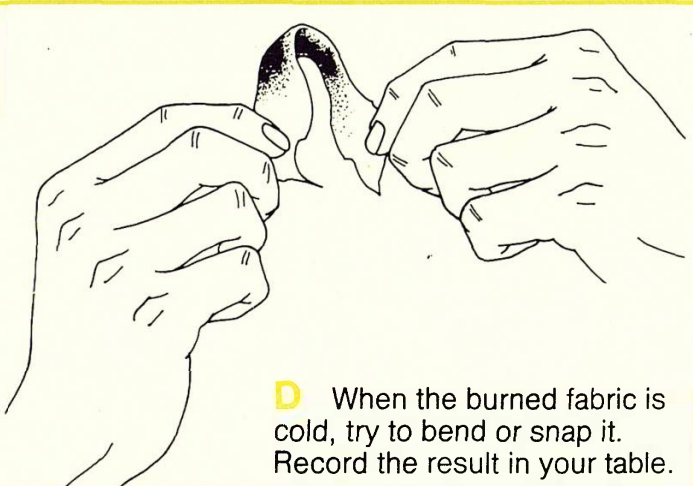

D When the burned fabric is cold, try to bend or snap it. Record the result in your table.

E Repeat steps A to D for the other fabrics.

F Use the chart on the next page to identify your numbered fabrics.



Information: Fabric identification chart

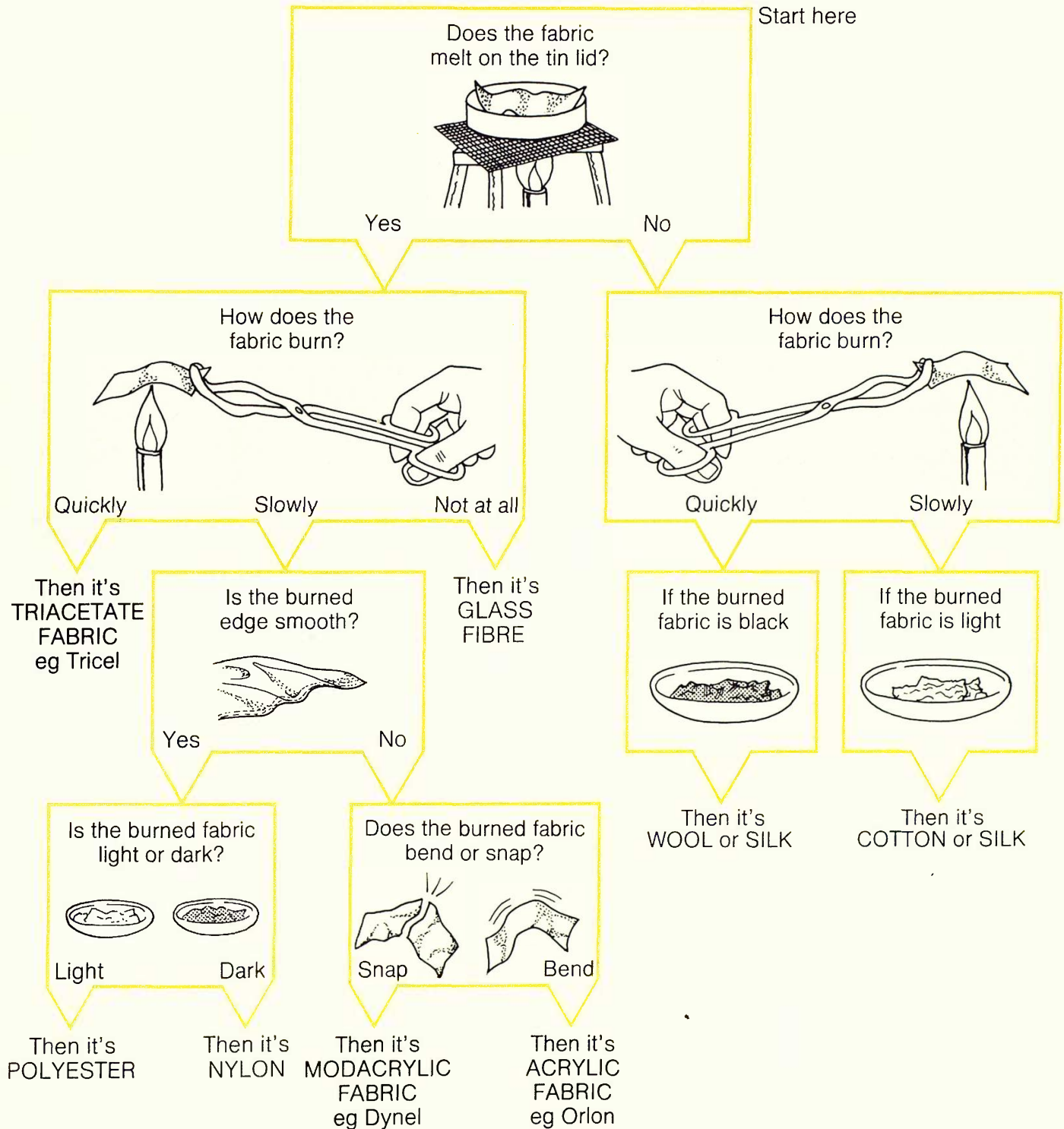

Q2 How would you tell the difference between wool and silk? (Clue: look at the work you did on page 1.)

Burning fabrics

Making fabrics flame resistant

Apparatus

- ★ flame proofer in beaker
- ★ 2 pieces of each type of fabric
- ★ Bunsen burner
- ★ heat proof mat
- ★ tongs
- ★ tweezers
- ★ stop clock
- ★ safety glasses
- ★ gloves

You are going to find out if soaking fabrics in flame proofer stops them burning.



Wear safety glasses and gloves. If any chemicals are splashed on your skin, wash them off immediately with soap and water.

Q3 Copy this table.

| Name of fabric | Time for unsoaked fabric to start burning (seconds) | Time for flame proofed fabric to start burning (seconds) |
|----------------|---|--|
| | | |

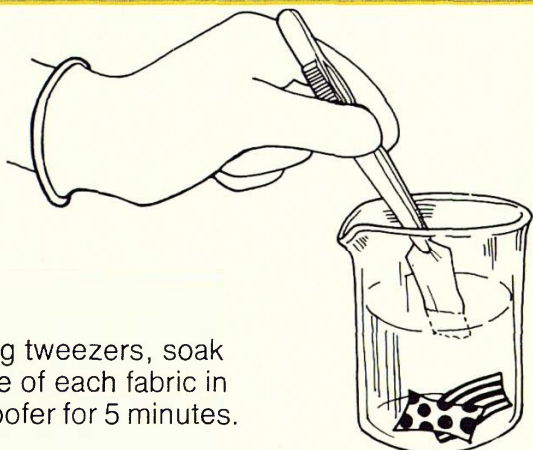

A Using tweezers, soak one piece of each fabric in flame proofer for 5 minutes.

B Remove the pieces and dry them.

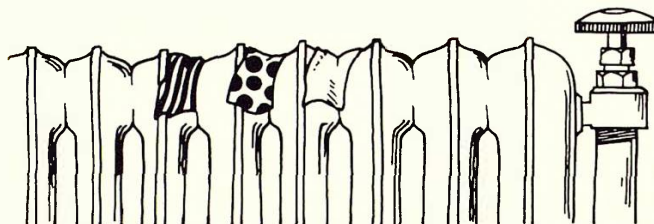

C Meanwhile, time how long the unsoaked fabrics take to **start** burning. Record the results in your table.

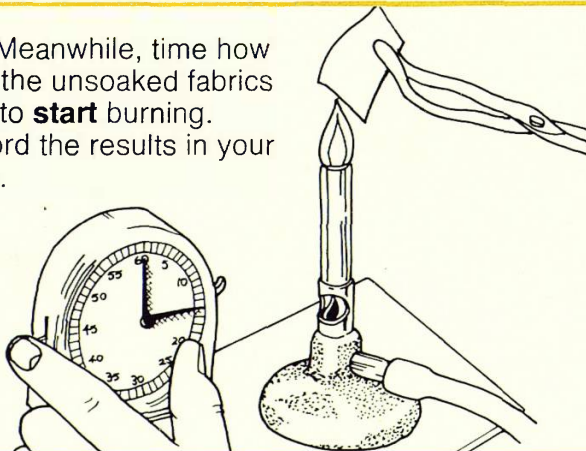

D Repeat step C with the dry, flame proofed fabrics. Record the results in your table.

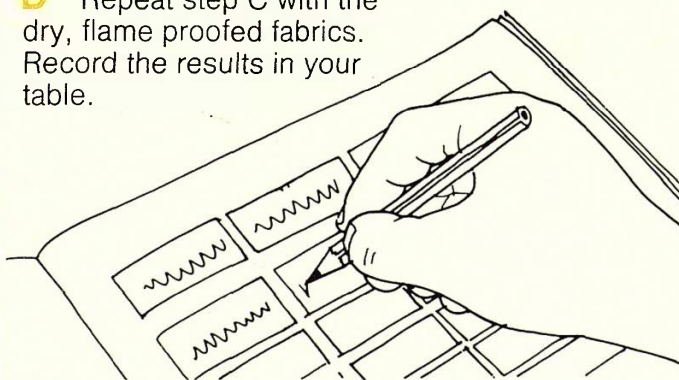

Q4 Which unsoaked fabric took the **shortest** time to start burning?

Q6 Did soaking in flame proofer stop any fabric burning?

Q5 Which unsoaked fabric took the **longest** time to start burning?

Information: Flame resistant clothing

All fabrics are affected by heat.



Fabrics used for clothing must withstand the heat of washing and ironing.

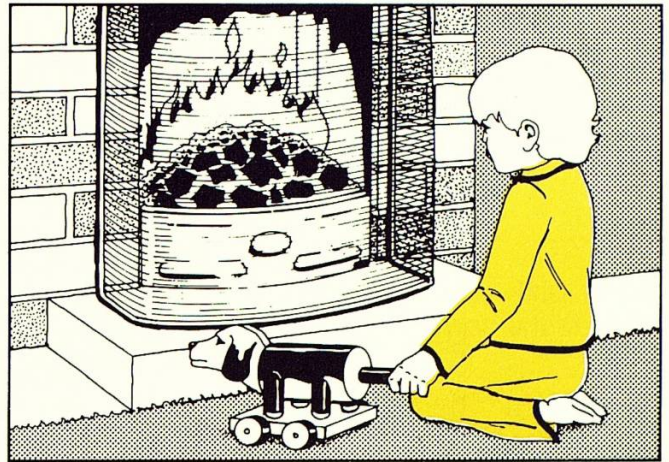

Clothes must not catch fire easily. For example, children's night-clothes must be flame resistant. If children are in a room with a fire, a fire guard should be used.



This label tells you that the nightdress is flame resistant.

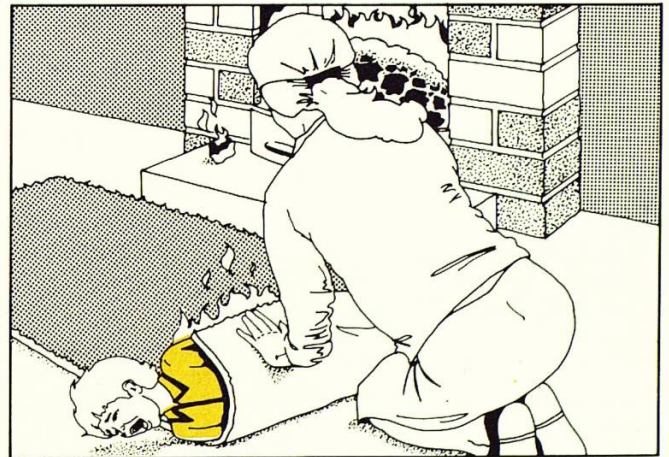

If a person's clothes catch fire, he must immediately be rolled in a rug. This keeps out the air.

Q7 When do clothes get hot?

Q9 What must you do if a person's clothes catch fire?

Q8 How would you find out if a nightdress was flame resistant?

3 Paper

Looking at the fibres in paper

Apparatus

- ★ newspaper
- ★ paper towel
- ★ drawing paper
- ★ handkerchief tissue
- ★ lamp
- ★ strawboard
- ★ small sheet of black paper
- ★ blotting paper
- ★ clear tape
- ★ glass slides
- ★ microscope

You are going to find out what sorts of fibres make up different types of paper.

A Lightly stick a piece of tape to the newspaper.

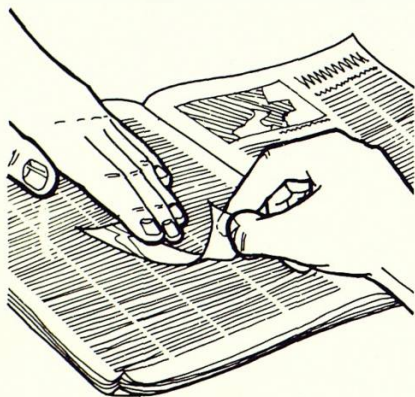

B Pull the tape off the paper.



C Stick the tape to a glass slide.

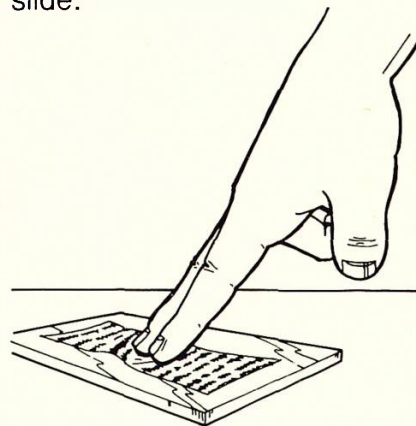

D Look at the slide by placing it on black paper.

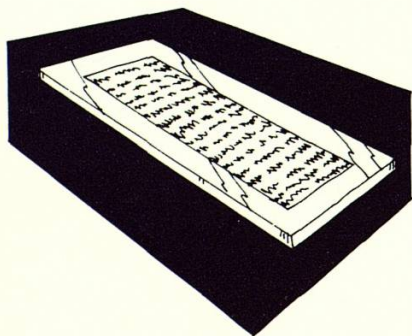

E Then put the slide under a microscope. Look at the length and thickness of the fibres.

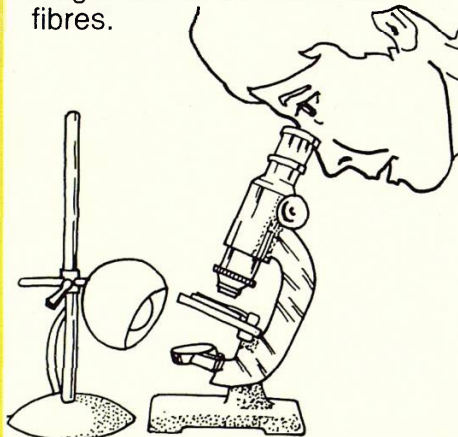

F Repeat steps A to E for each type of paper.

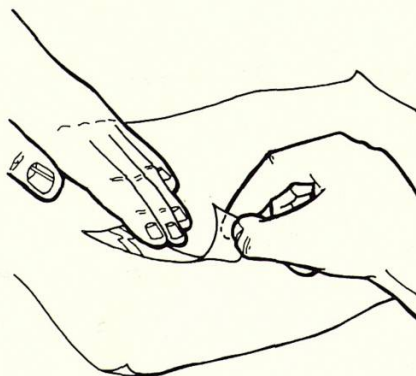

Q1 Which paper has the longest fibres?

Q2 Which paper has the shortest fibres?

Q3 Which paper has the thinnest fibres?

Q4 Which paper has the thickest fibres?

Making paper

Apparatus

- ★ cotton wool ★ a piece of felt or blanket ★ rolling pin ★ 2 sheets of metal
- ★ mortar and pestle ★ pencil ★ felt tip pen ★ wire gauze ★ beaker of water

You are going to rearrange the fibres in cotton wool to make paper.

A Put a large piece of cotton wool in a mortar. Add a **small** amount of water. Pulp with a pestle.

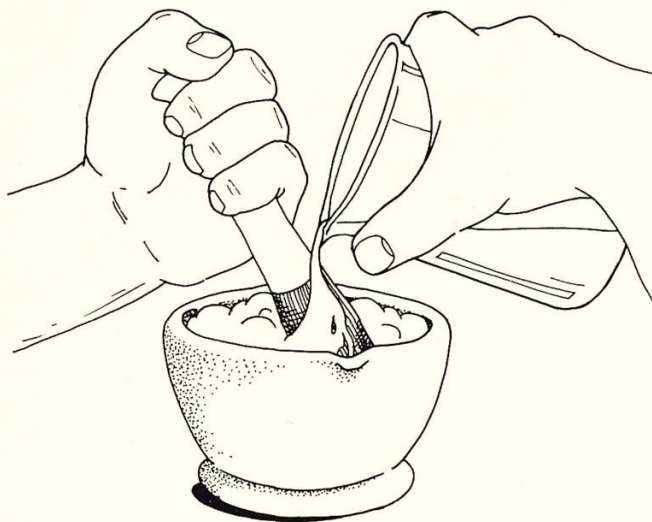

Carry on pulping and adding water until the cotton wool looks like porridge.

B Put your pulp on a gauze to strain. Hold them over the sink.

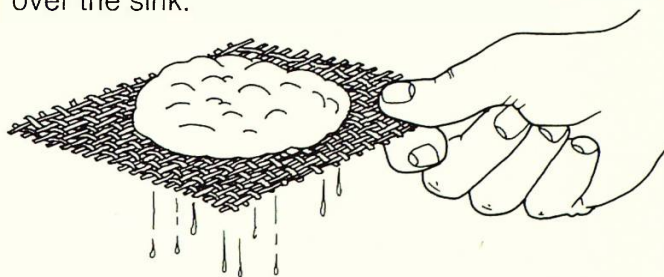

C Cover the pulp with felt or blanket. Squash the pulp flat.

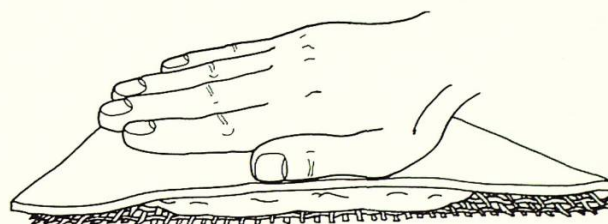

D Put the squashed pulp between two sheets of metal and roll flat. Then let your paper dry.

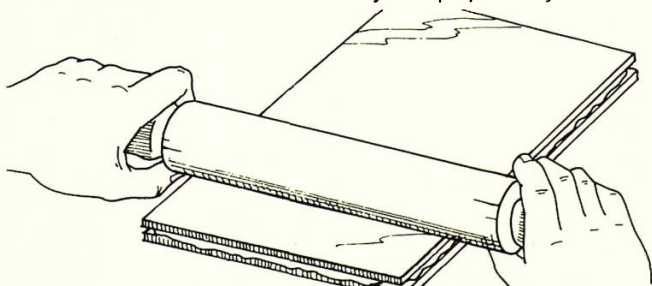

E Stick a piece of your paper in your book. Try to write on it with a pencil and a felt-tip pen.

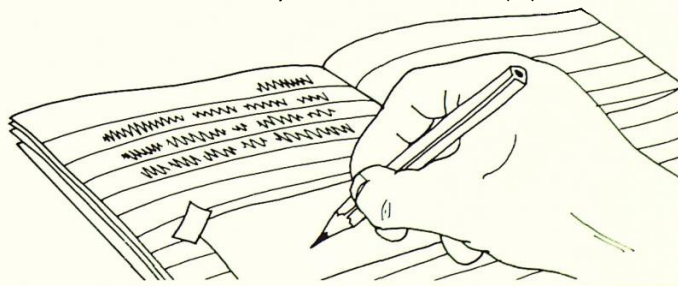

Q5 Why do you use cotton wool to make paper?

Q6 What are you doing to the fibres in cotton wool when you pulp them in a mortar?

Q7 Can you write on your paper with a pencil or felt-tip pen?

Paper

Information: Paper

Paper is made from fibres. Usually, the fibres come from wood. Sometimes, they come from rags or small plants.

The stages in paper making.

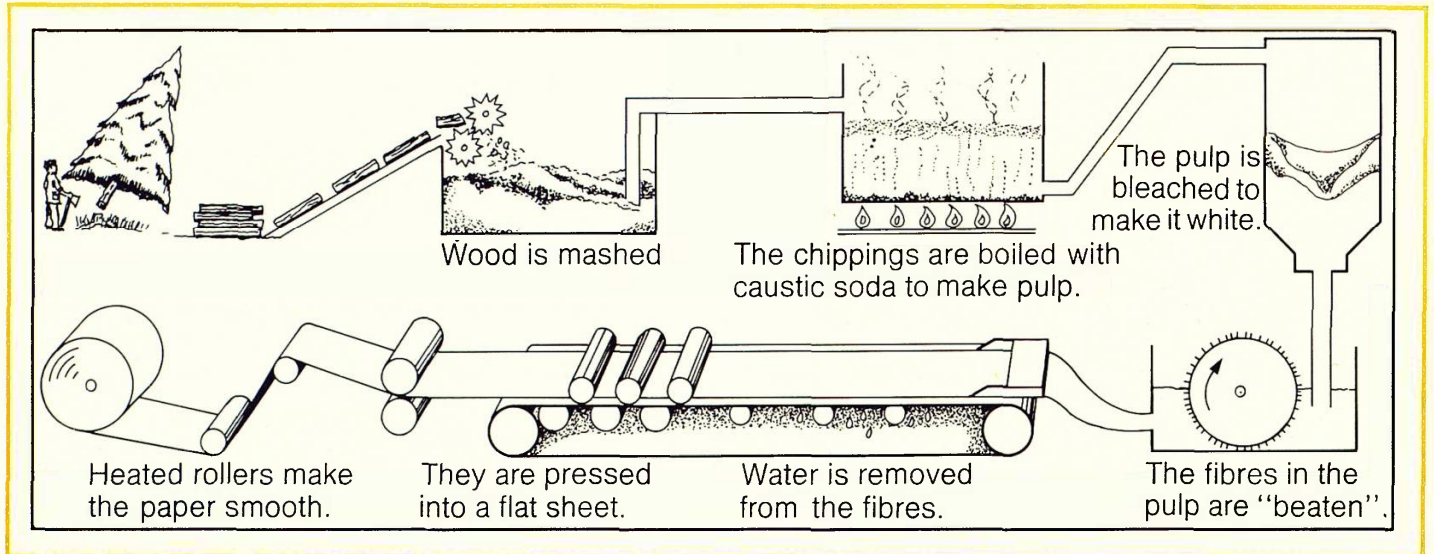

Recycling

Waste paper can be used again, or **recycled**. A de-inking process is used. The paper made is often of poor quality, and used for packing.

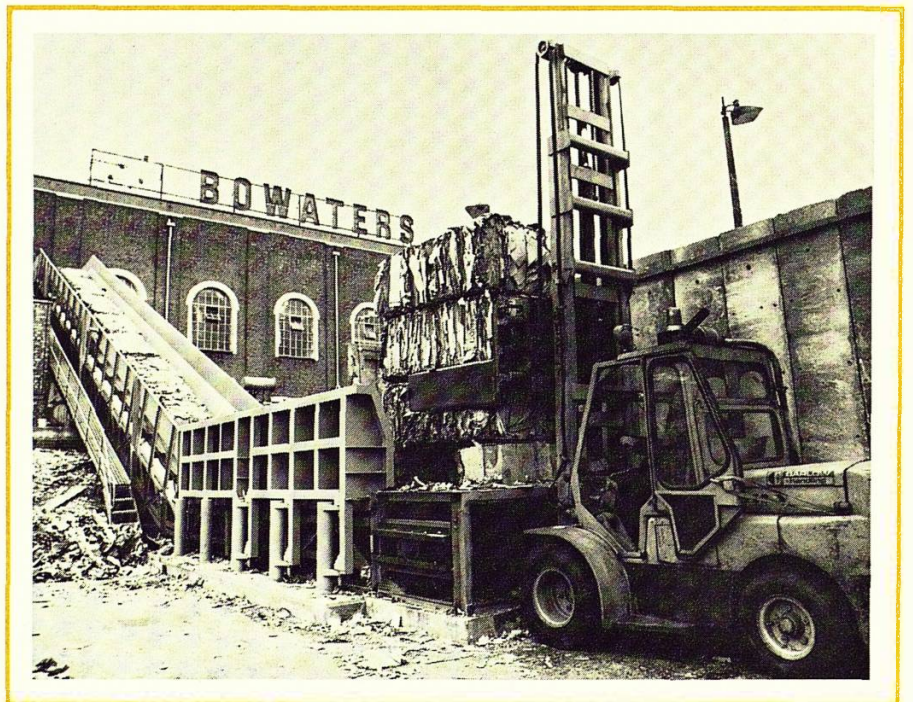

Q8 What do all the materials used to make paper have in common?

Q9 Why is wood pulp bleached?

Q10 What does recycling mean?

Q11 Why is it important to recycle paper?

4 Making fibres

Making nylon

Apparatus

- ★ 5 cm³ beaker
- ★ solution A
- ★ solution B
- ★ safety glasses
- ★ gloves
- ★ tweezers
- ★ glass rod

You are going to mix two chemicals to make a fibre, nylon.

 Wear safety glasses and gloves. If any chemicals are splashed on your skin, wash them off immediately with soap and water.

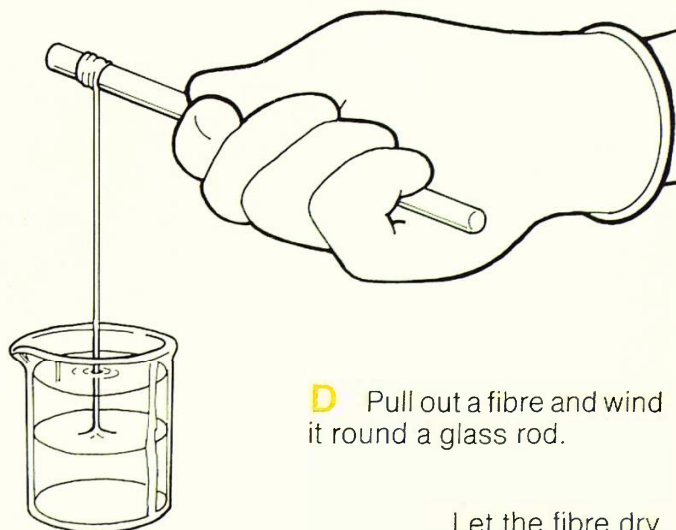
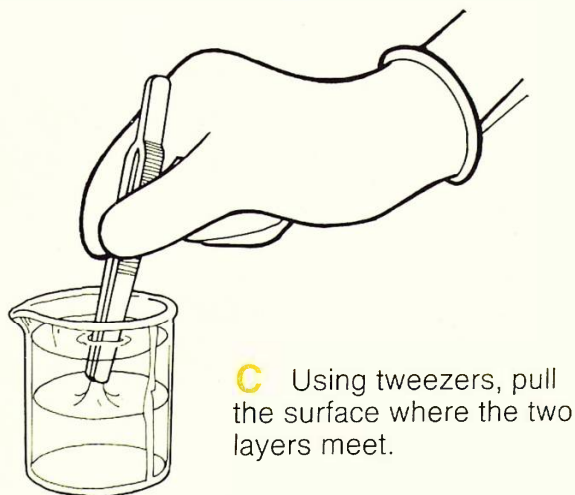
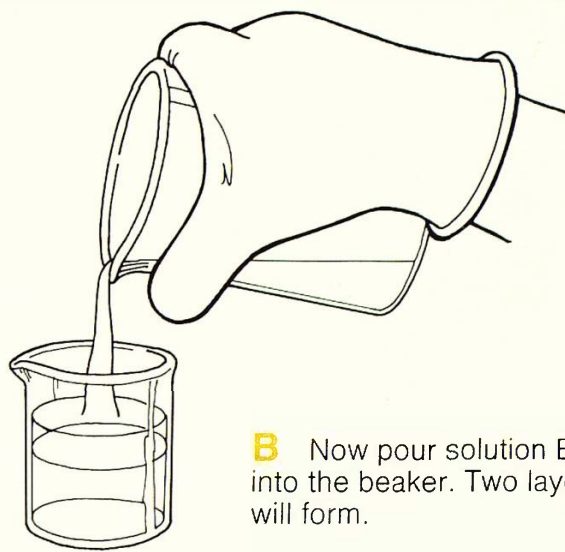
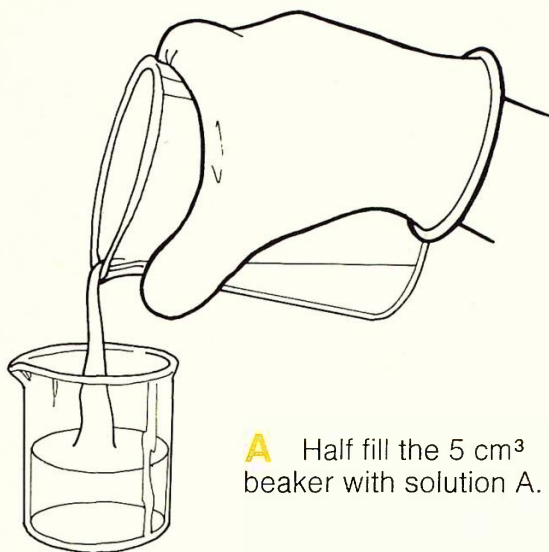

Q1 Describe the nylon fibre.

Where in the beaker does the nylon form? Why is this?

Making fibres

Making rayon

Apparatus

- ★ spatula
- ★ three 250 cm³ beakers
- ★ glass rod
- ★ sulphuric acid
- ★ ammonia solution
- ★ syringe
- ★ copper carbonate
- ★ safety glasses
- ★ filter papers

You are going to rearrange the fibres in paper to make rayon.

 Wear safety glasses.

A Put 150 cm³ ammonia in a 250 cm³ beaker.

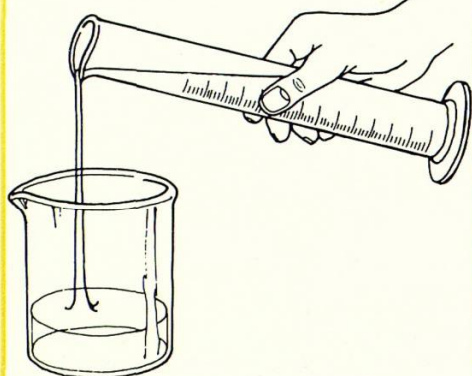

B Add copper carbonate and stir until no more dissolves.

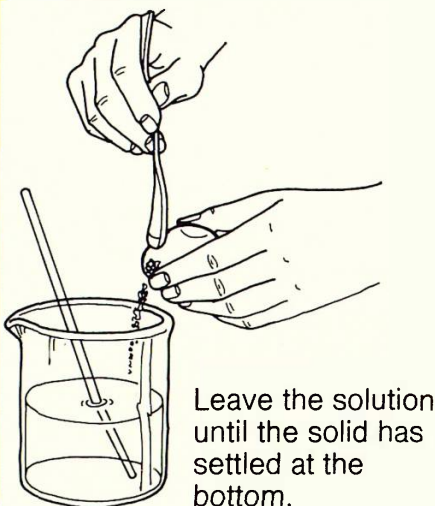

C Carefully pour off the blue liquid into another beaker.



D Add small pieces of filter paper. Stir with the glass rod. Carry on until the blue liquid is like syrup.



E Take up some of the blue liquid into a syringe.

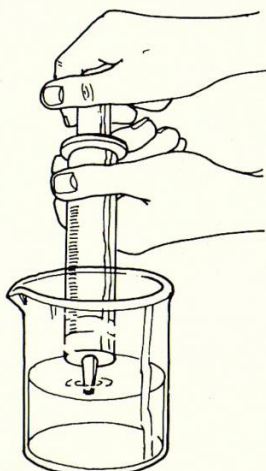

F Half fill an empty beaker with sulphuric acid. Put the nozzle of the syringe into the acid. Carefully push the plunger of the syringe until all the blue liquid is mixed with the acid.

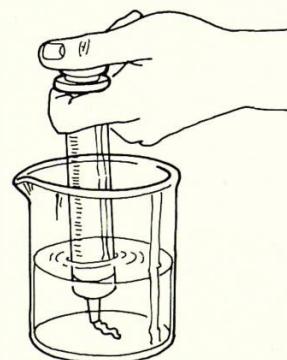

Q3 What does the rayon look like?

Information: Man-made fibres

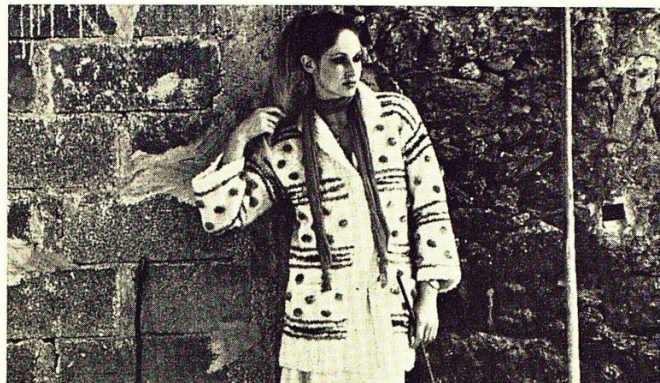

Until 70 years ago, all cloth was made from natural fibres. Some natural fibres are still used – as in this wool jacket.

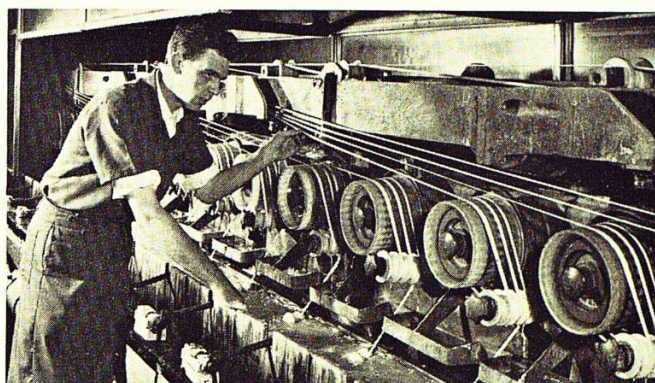

Rayon was the first man-made fibre. It is made from wood pulp or cotton. Because it looks and feels like silk, it is called 'artificial silk'. These rayon fibres are being pulled from an acid "bath" and wound.

Nylon

Nylon is another man-made fibre. It is made from chemicals. The chemicals come from coal, oil or natural gas. The photograph shows nylon being spun.

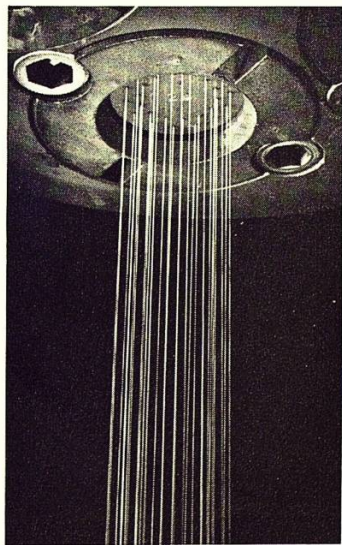

Nylon was first produced in about 1935. It is used to make many things – strings for tennis racquets, the covers of tennis balls and cloth for these tracksuits.



Q4 Name a natural fibre.

Q5 What was the first man-made fibre?

Q6 When was nylon first produced?

Q7 What properties does nylon have?

Q8 Why did you use filter paper in the making of rayon?

5 The strength of fibres

Testing thread to destruction

Apparatus

- ★ clamp and stand
- ★ a weight hanger and slotted weights
- ★ "G" clamp
- ★ ruler
- ★ pieces of sticky paper
- ★ samples of threads of equal thickness
- ★ split bung

You are going to find the strength of different threads. (Threads are made by twisting fibres together).

Q1 Copy this table. (You need one table for each thread you test.)

| | |
|-----------------------------|--|
| Name of thread _____ | Mass added when thread snapped _____ |
| Mass (weight) added (grams) | Distance between markers (centimetres) |
| 100 | |
| 200 | |

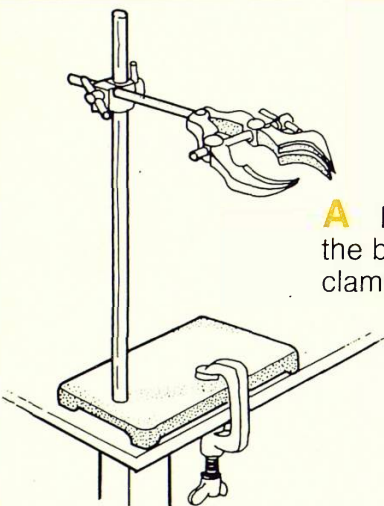

A Fix a clamp stand on the bench with a "G" clamp.

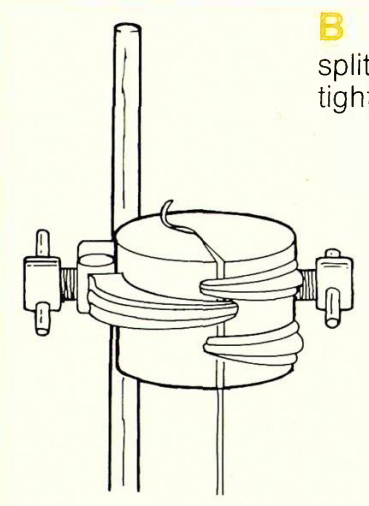

B Put a thread into the split bung. Clamp the bung tightly.

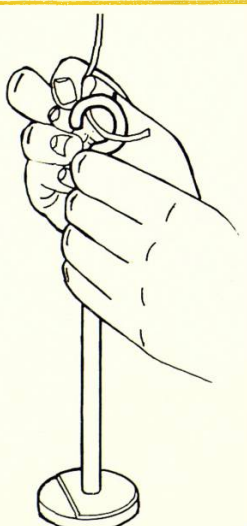

C Tie the weight hanger on to the thread.

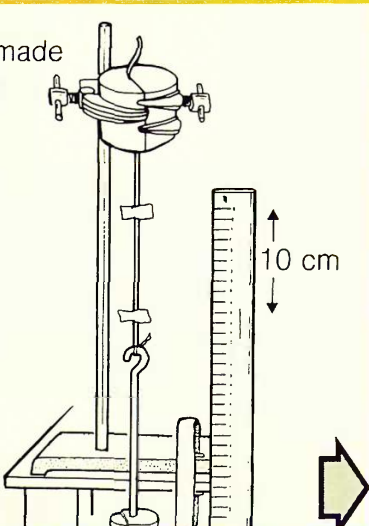

D Put two markers (made of sticky paper) on the thread, 10 cm apart.

The strength of fibres

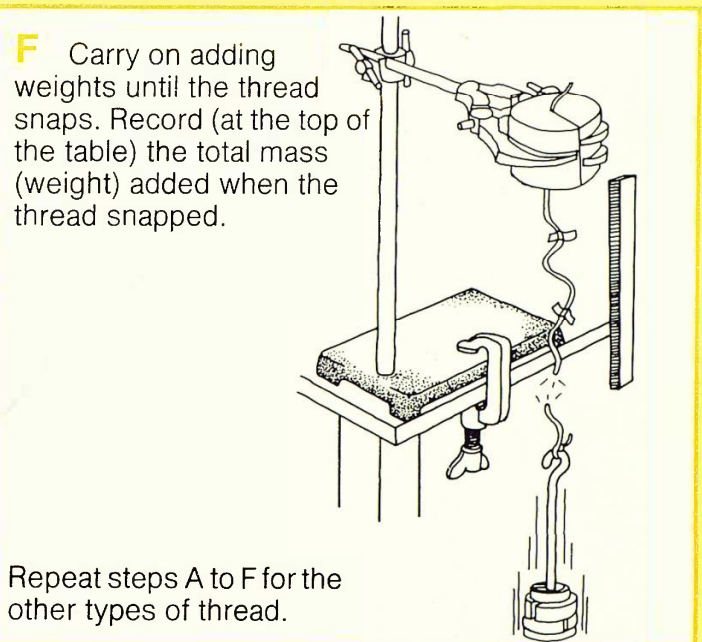
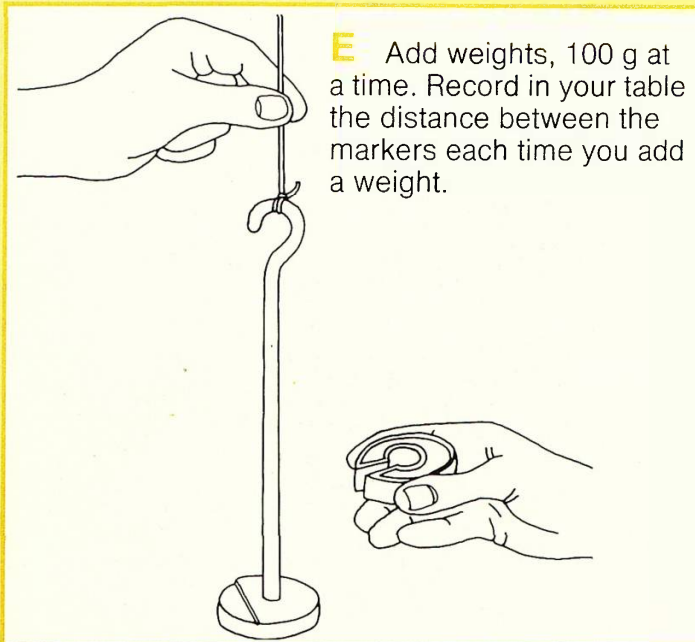

Q2 Draw a graph like this of your results. Plot distance between markers against mass (weight) added. Use a different colour for each thread. Label each line.

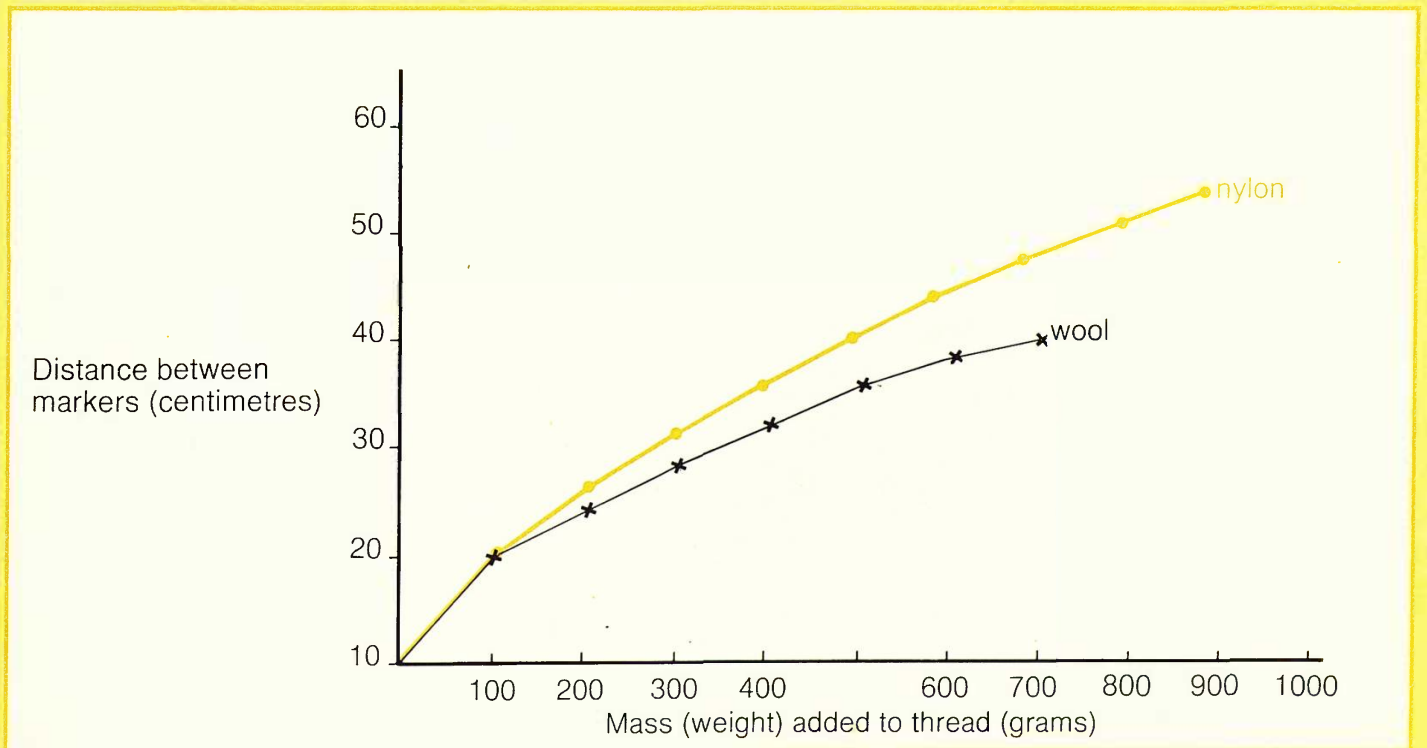

Q3 Which thread held the heaviest mass (weight)? (This is the strongest thread.)

Q5 Which thread stretched the most?

Q4 Which was the weakest thread?

The strength of fibres

Information: Ropes



The ropes on this sailing ship were made of natural fibres – Manila and Sisal. Some ropes were thicker than others, for extra strength. The problems with natural fibres are that they rot, and that the colour and stiffness cannot be changed.

This rock climber's life depends on his rope. Most modern ropes are made from man-made fibres. They can be made in any colour, strength or stiffness. These ropes do not rot, but they are damaged by sunlight, high temperatures and chemicals.



Making ropes

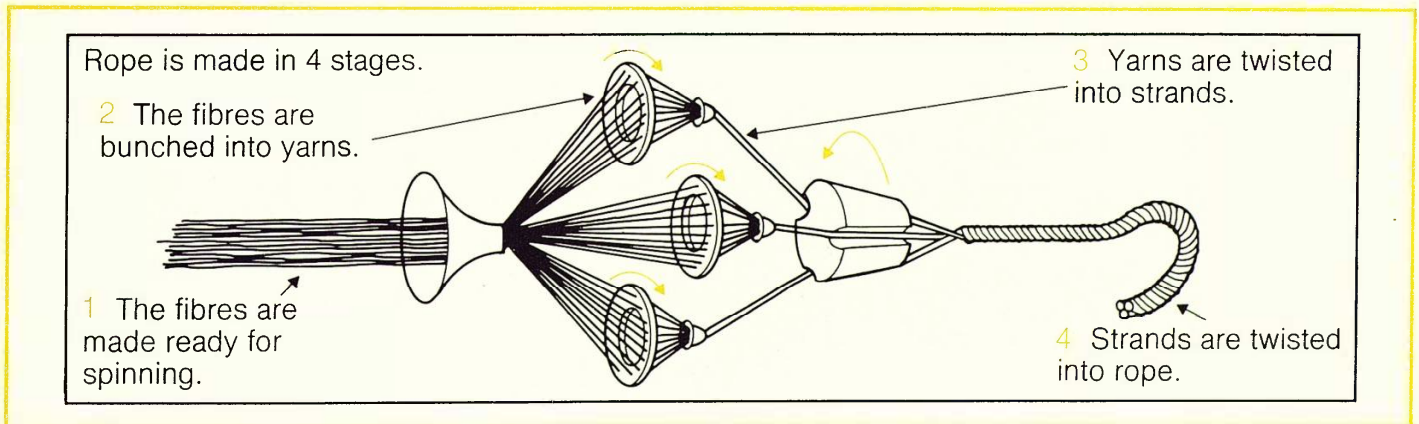

Q6 Which natural fibres are used to make rope?

Q7 Put in order of size: **yarn, rope, strand, fibre.**

Q8 Why are yarns twisted one way, and strands the other?

Q9 What are the advantages of using a rope made of man-made fibres?

Q10 What can damage ropes made of man-made fibres?

6 The wear of fabrics

Investigating wear

Apparatus

★ wear wheel ★ stop clock ★ samples of fabrics ★ scissors ★ glue

You are going to find out which fabrics stand up to the wear (rubbing).

Q1 Copy this table.

| Name of fabric | Number of fabric | Piece of unworn fabric | Piece of worn fabric |
|----------------|------------------|------------------------|----------------------|
| | | | |

A Cut each piece of fabric in half. Stick one half in the "unworn" column of your table.



B Fix the other half of each piece on the wear wheel. Record the number of each fabric in your table.

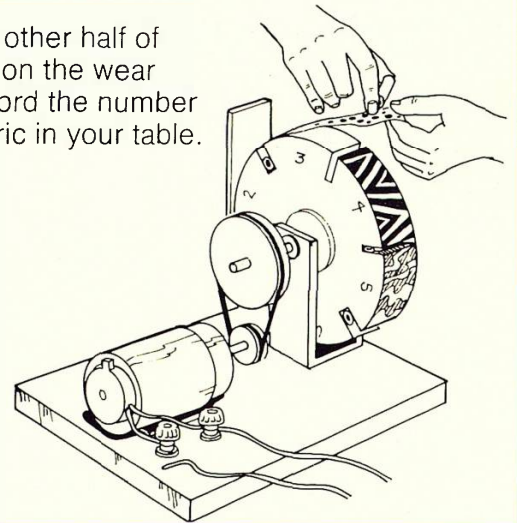

C Turn the wheel for 5 minutes, making sure the sandpaper touches the fabrics.

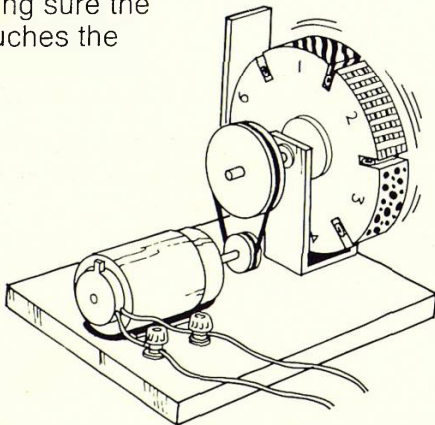

D Take the fabrics off the wheel. Stick them in the "worn" column of your table.

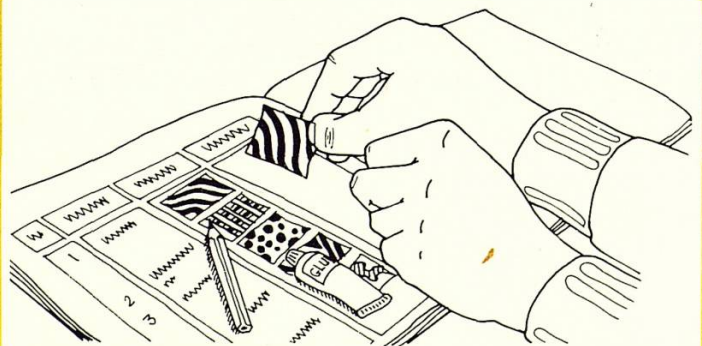

Q2 In which fabrics did holes, tears or loose threads appear?

Q4 In which fabrics did the colour or pattern fade?

Q3 Which fabrics became shiny?

Information: Standing up to wear

The fabrics of clothes and furnishings are rubbed each time they are used. They are also rubbed during washing. The lifetime of a fabric depends on how it stands up to this wear. Some fabrics have better wear resistance than others.

Making fabrics stronger

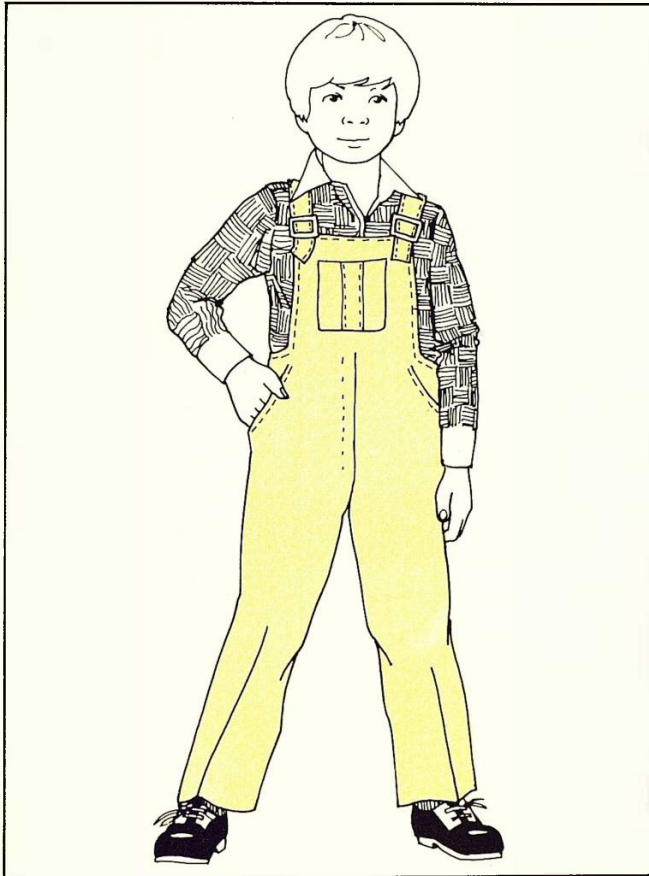

Children's clothes take a lot of wear. This fabric is a mixture of wool and polyester. The wool gives the fabric warmth and the polyester strength.

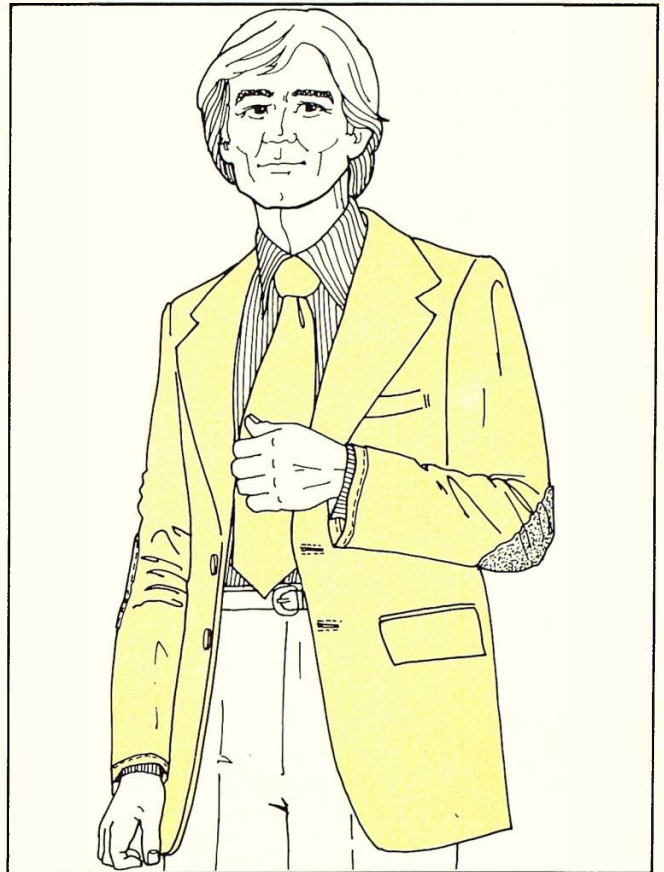

This jacket has patches at the cuffs and elbows to increase wear resistance. It will last longer if it is made from good quality wool. Hand-woven fabrics are tougher than machine-woven fabrics, because the fibres are woven at a lower tension.

Q5 What does **wear resistance** mean?

Q6 Write down two ways of making fabrics stronger.

Q7 How could you make the knees of a pair of trousers stand up to wear?

7 Fabrics as insulators

Investigating fabrics as insulators

Apparatus

- ★ 2 fabric samples
- ★ sticky tape
- ★ beaker with polystyrene in the base
- ★ tripod
- ★ stop clock
- ★ thermometer
- ★ polystyrene lid
- ★ copper vessel
- ★ heatproof mat
- ★ cloth
- ★ tongs
- ★ 250 cm³ beaker
- ★ gauze
- ★ Bunsen burner

You are going to find out if fabrics help to keep the heat in a vessel of hot water.

Q1 Copy this table.

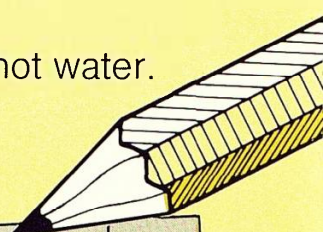

| Time (minutes) | 0 | 2 | 4 | 6 | 8 | 10 | 12 | 14 | 16 |
|---|---|---|---|---|---|----|----|----|----|
| Water temperature (°C), vessel covered in fabric 1 | | | | | | | | | |
| Water temperature (°C), vessel covered in fabric 2 | | | | | | | | | |
| Water temperature (°C), vessel surrounded by air | | | | | | | | | |

A Boil about 100 cm³ water in a beaker.

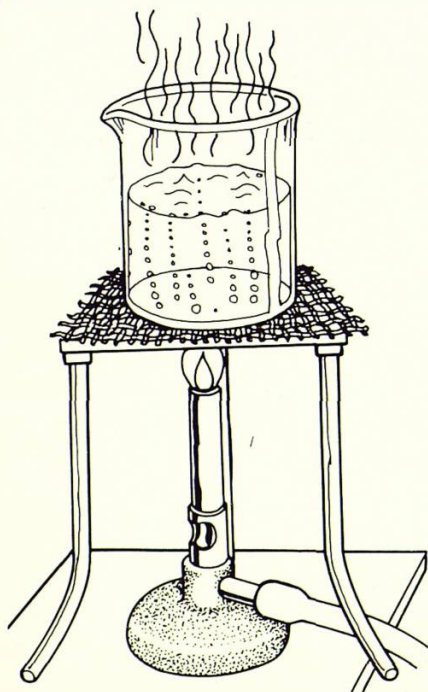

B Tape fabric 1 around the copper vessel.



C Put the fabric-covered vessel in a glass beaker.

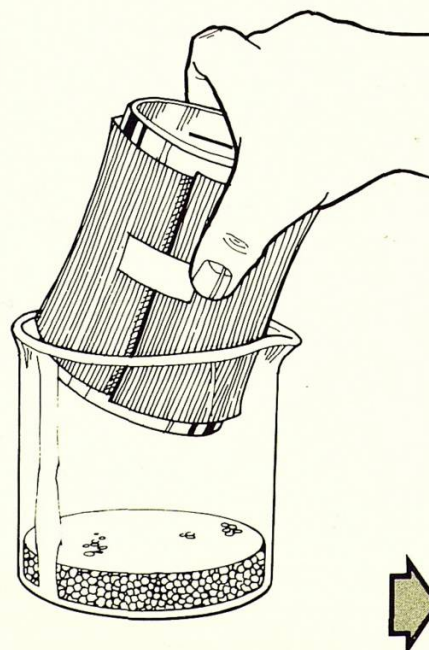

Fabrics as insulators

D Using a cloth, pour hot water into the copper vessel. Stop when the water reaches the mark inside.

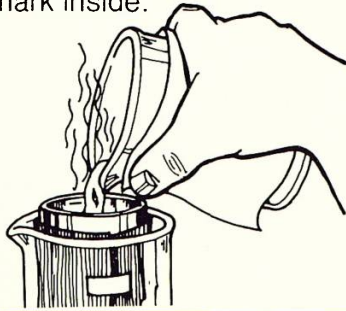

E Put the lid and thermometer into the vessel. Start the stop clock.

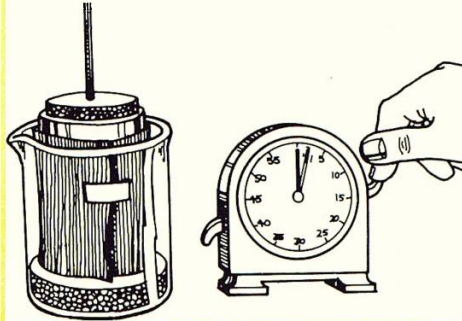

F Take the temperature every 2 minutes for 16 minutes. Record the results in the first row of your table.

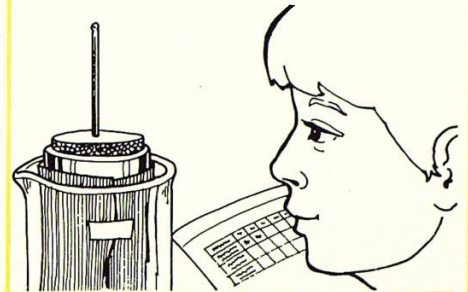

G Repeat steps A to F, using fabric 2. Record the results in the second row of your table.

H Repeat steps A to F with no fabric around the copper vessel. Record the results in the third row of your table.

Q2 Draw a graph like this of your results. Plot temperature against time. Use a different colour for each line. Label each line.

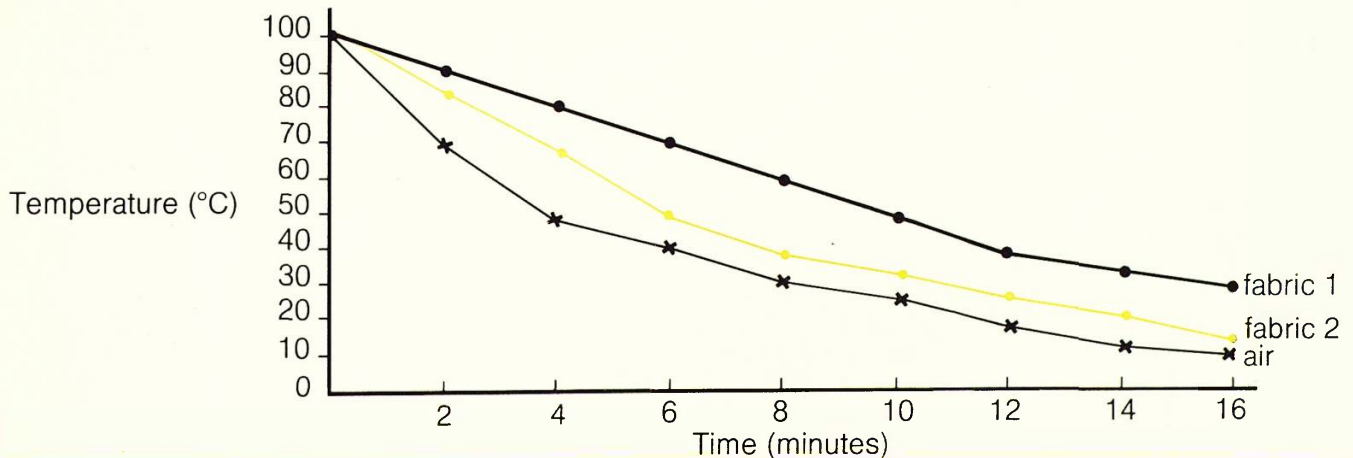

Q3 Look at your graph.

- How much did the temperature of the water surrounded by fabric 1 drop in 16 minutes?
- How much did the temperature of the water surrounded by fabric 2 drop in 16 minutes?

(c) How much did the temperature of the water surrounded by air drop in 16 minutes?

Q4 Of your two fabrics and air, which keeps water warm longest? (In other words, which is the best insulator?)

Fabrics as insulators

Information: Keeping warm or cool

The human body must be kept at about 37 °C if it is to work properly.



The body sweats to keep cool, shivers to warm up.



Insulating the body

Clothes help to keep the body warm. All fabrics have air trapped amongst their fibres. The more trapped air, the better the fabric is at keeping in the heat.

This anorak has padding to trap air and keep the wearer warm.



This wetsuit is made of neoprene rubber. There are tiny air bubbles in the rubber which insulate the wearer.



Insulating houses

Houses are built with cavity walls for insulation. The air trapped between the walls keeps heat in. Sometimes the space between the walls is filled with foam.



Q5 What is the normal temperature of the human body?

Q6 How does a padded anorak help to keep a climber warm?

Q7 What is an insulator?

Q8 How is foam used to insulate a house?

8 Shrinkage

Washing fabrics

Apparatus

- ★ 3 samples of material
- ★ ruler
- ★ tripod
- ★ heatproof mat
- ★ cloth
- ★ Bunsen burner
- ★ thermometer
- ★ glue
- ★ gauze
- ★ glass rod
- ★ soap solution
- ★ beaker
- ★ laundry marker

You are going to find out if fabrics change their size when they are washed.

A Using a laundry marker, draw a 5 cm x 5 cm square on each fabric sample.

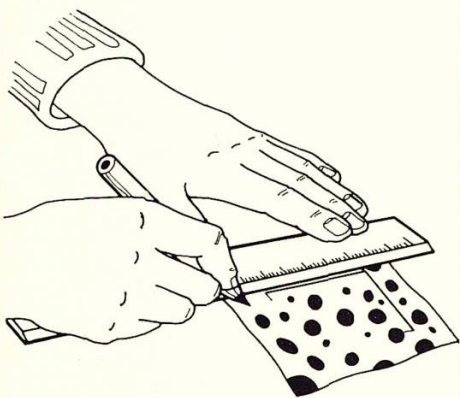

B Half fill a beaker with soap solution. Heat to 60 °C.

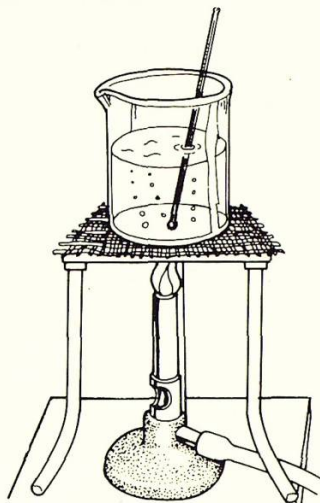

C Using a cloth, put the beaker on a heatproof mat. Add the samples of "washing" and stir for 10 minutes.

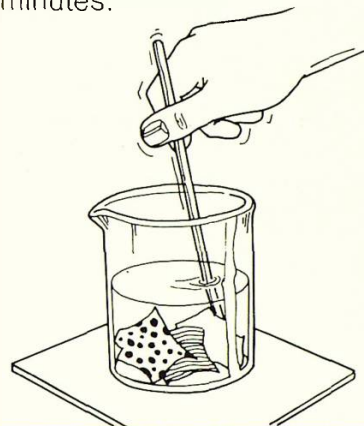

D Remove the "washing". Rinse out all the soap.

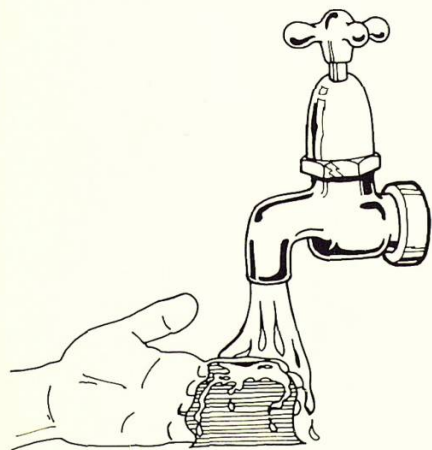

E Dry the "washing".

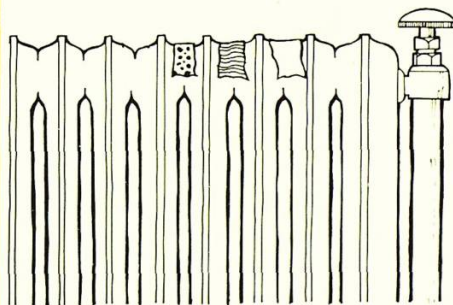

F Stick the dry samples in your book. Measure each sample again. Write the new measurement beside each sample.

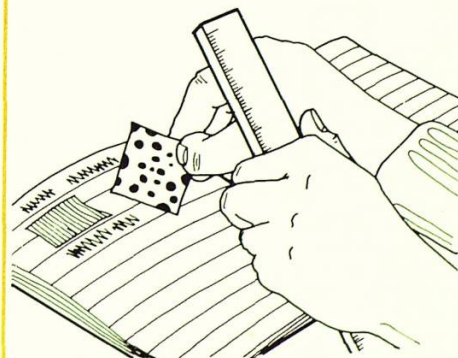

Q1 What were the sizes of the squares after washing?

Q3 Which material shrunk the most?

Q2 Which material shrunk the least?

Shrinkage

Information: Care of fabrics

Fabrics may change when they are washed. Natural and man-made fabrics change in different ways.

Most clothes carry a care label. This tells you how to wash the clothes. It may also give information about bleaching, ironing and dry cleaning the clothes.

The care label is made up of symbols. The symbols were worked out by the Home Laundering Consultative Council (HLCC for short).

The care label has four symbols.

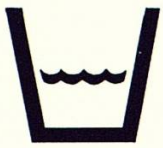

A washing symbol.



An ironing symbol.



A bleaching symbol.

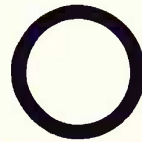

A dry-cleaning symbol.

Washing symbols

| Symbol | Maximum temperature (machine wash) | Maximum temperature (hand wash) | Agitation | Rinse | Spinning/wringing |
|--------|------------------------------------|---------------------------------|--------------------|--------|-------------------------------|
| | Very hot (95 °C) | Hand hot (50 °C) | Maximum | Normal | Normal |
| | Hot (60 °C) | Hand hot (50 °C) | Maximum | Normal | Normal |
| | Hot (60 °C) | Hand hot (50 °C) | Medium | Cold | Short spin or drip dry |
| | Hand hot (50 °C) | Hand hot (50 °C) | Medium | Cold | Short spin or drip dry |
| | Warm (40 °C) | Warm (40 °C) | Medium | Normal | Normal |
| | Warm (40 °C) | Warm (40 °C) | Minimum | Cold | Short spin |
| | Warm (40 °C) | Warm (40 °C) | Minimum do not rub | Normal | Normal spin do not hand wring |
| | Cool (30 °C) | Cool (30 °C) | Minimum | Cold | Short spin do not hand wring |
| | Very hot (95 °C) | Hand hot (50 °C) | Maximum | Cold | Drip dry |
| | Do not machine wash | | | | |
| | Do not wash | | | | |

Bleaching symbols



This symbol means bleach can be used.



This symbol means bleach must **not** be used.

Ironing symbols

The ironing temperature is shown by the number of dots in the symbol.



cool



warm



hot



do not iron

Dry cleaning symbols



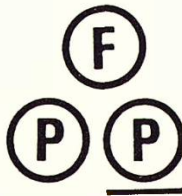

Dry clean with any solvent (liquid).



These symbols mean a special solvent has to be used to clean the clothes. So take the clothes to a dry cleaners.



Do not dry clean.

- Q4** What is a care label?
- Q5** What does HLCC stand for?
- Q6** What do these symbols mean?
- (a)  (b)  (c) 
- Q7** What does 40° mean in this symbol?



- Q8** Here are two labels. What do they mean?



- Q9** What is a solvent?

9 Detergents

What detergents do

Apparatus

- ★ 2 pieces of writing paper
- ★ 2 pieces of greaseproof paper
- ★ 2 pieces of glass
- ★ 2 pieces of cotton fabric
- ★ liquid detergent
- ★ 2 droppers
- ★ beaker of water

You are going to find out how a detergent affects drops of water.

Q1 Copy this table.

| Name of material | Shape of water drop on material | Shape of water drop on material + detergent |
|------------------|---------------------------------|---|
|------------------|---------------------------------|---|

A Put one drop of water on the writing paper.

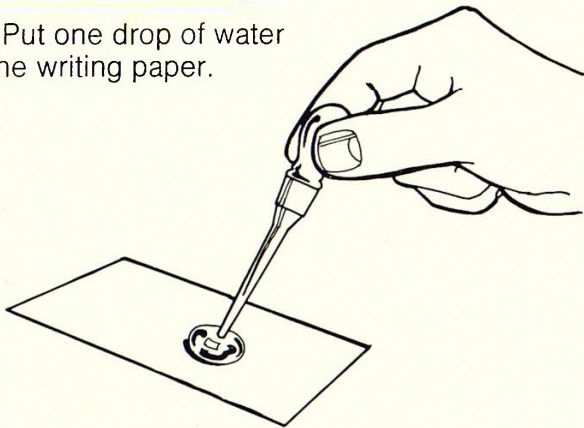

B Look at the drop from the side. Draw the shape of the drop in the middle column of your table.

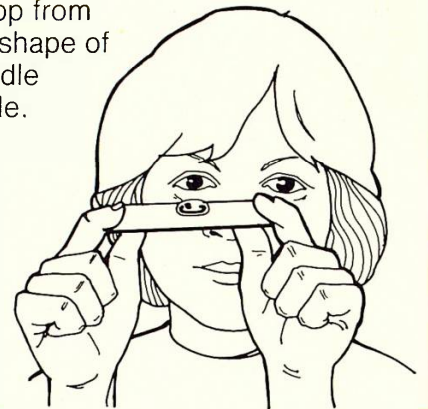

C Rub 1 drop of detergent onto the second piece of writing paper. Rub it with your finger.

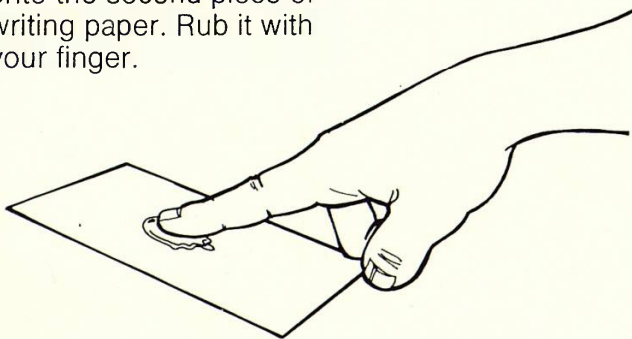

D Put one drop of water on the rubbed-in detergent. Look at it from the side. Draw the shape of the drop in the last column of your table.

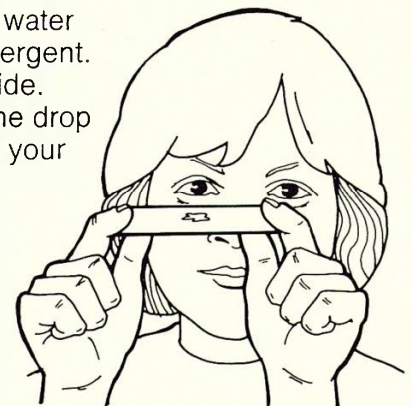

E Repeat steps A to D with the other materials.

Q2 Are all the drop shapes the same?

Q3 Did the detergent make any difference to the drop shapes?

Q4 If a drop is flat the water must have gone into the material. How many of your materials were wetted in this way?

Cleaning fabrics

Apparatus

- ★ 1 clean piece of fabric ★ 6 dirty pieces of fabric ★ glass rods
- ★ 6 numbered beakers ★ tweezers ★ syringe ★ glue ★ hot water
- ★ liquid detergent ★ laundry marker ★ stop clock

You are going to find out the best way to clean dirty cotton fabric.

Q5 Copy this table.

| Beaker number | Cold water | Hot water | Detergent | Stir | Piece of the fabric |
|---------------|------------|-----------|-----------|------|---------------------|
| 1 | ✓ | | | | |
| 2 | | ✓ | | | |
| 3 | ✓ | | ✓ | | |
| 4 | | ✓ | ✓ | | |
| 5 | ✓ | | ✓ | ✓ | |
| 6 | | ✓ | ✓ | ✓ | |

A Half-fill the beakers with cold or hot tap water as shown in the table.

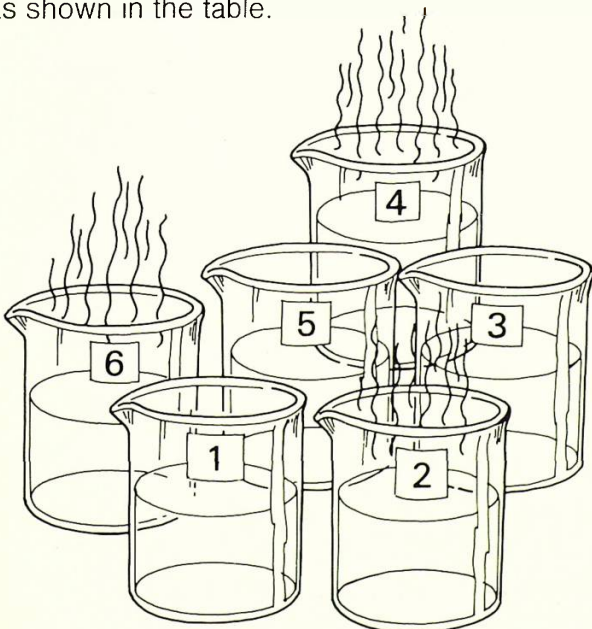

B Using a syringe, put 1 cm³ of detergent in beakers 3, 4, 5 and 6.

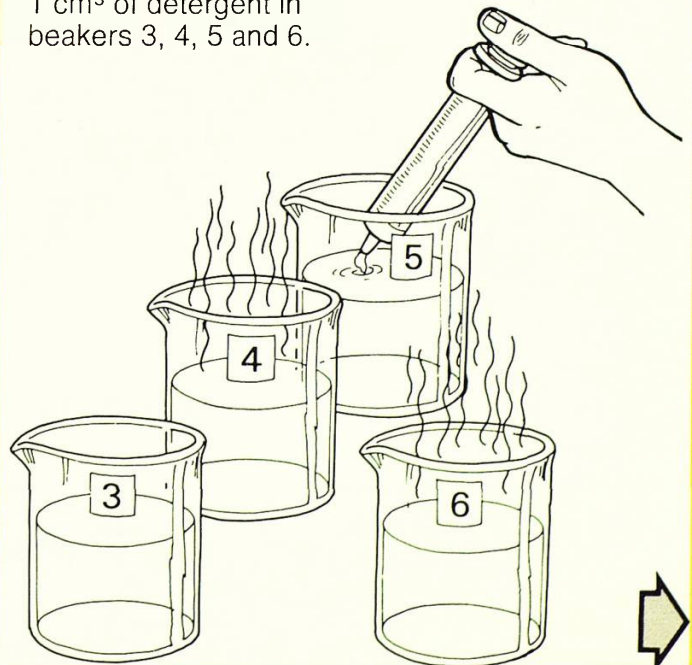

Detergents

C Number each piece of dirty fabric with a laundry marker. Put the correctly numbered piece in each beaker. Leave beakers 1, 2, 3 and 4 for five minutes.

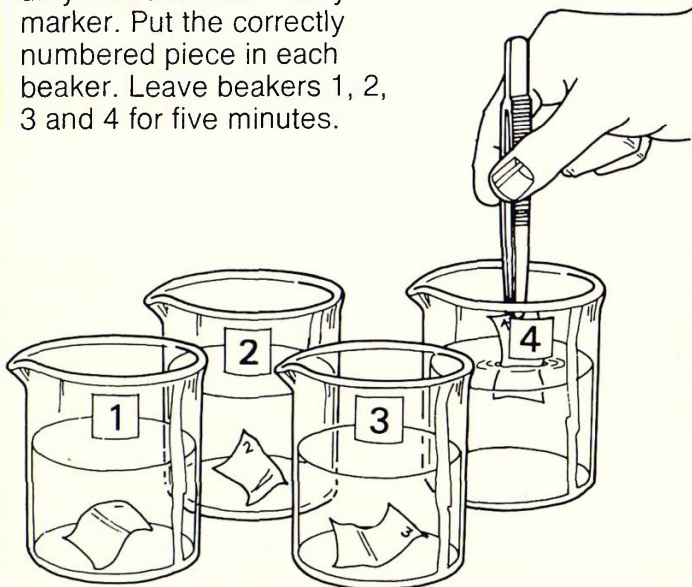

D Stir the fabric in beakers 5 and 6 for five minutes.

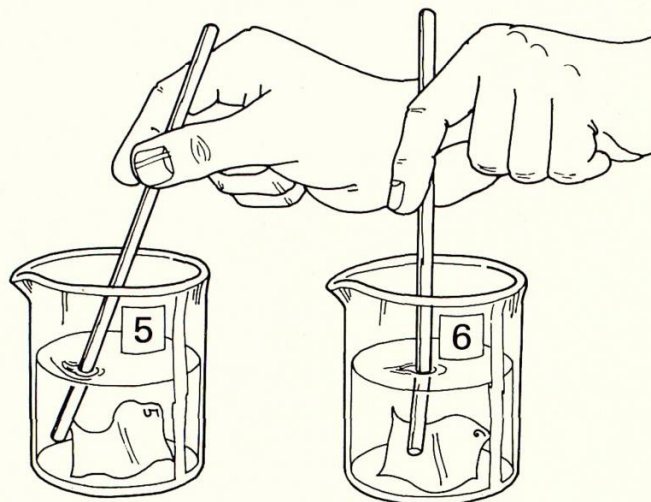

E Remove the "washing" from all the beakers. Rinse.

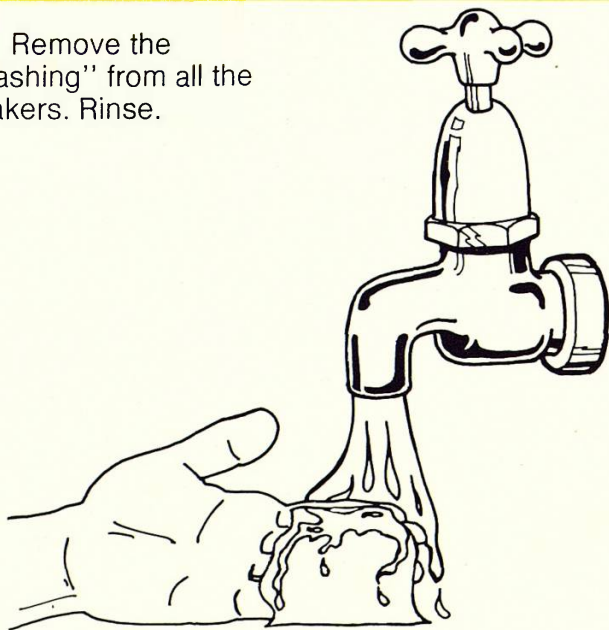

F Dry the "washing".

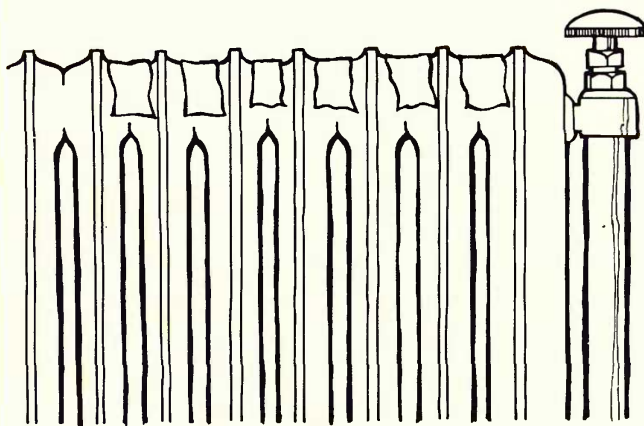

G Stick the dry, washed fabrics in the last column of your table. Also stick an unwashed, clean piece of fabric in your book.

Q6 Were the 6 pieces of dry washing as clean as the one clean piece?

Q8 Does heat help to clean the fabric?

Q7 Does stirring (or agitation) help to clean the fabric?

Q9 What are the best conditions for washing fabric?

Information: How detergents work

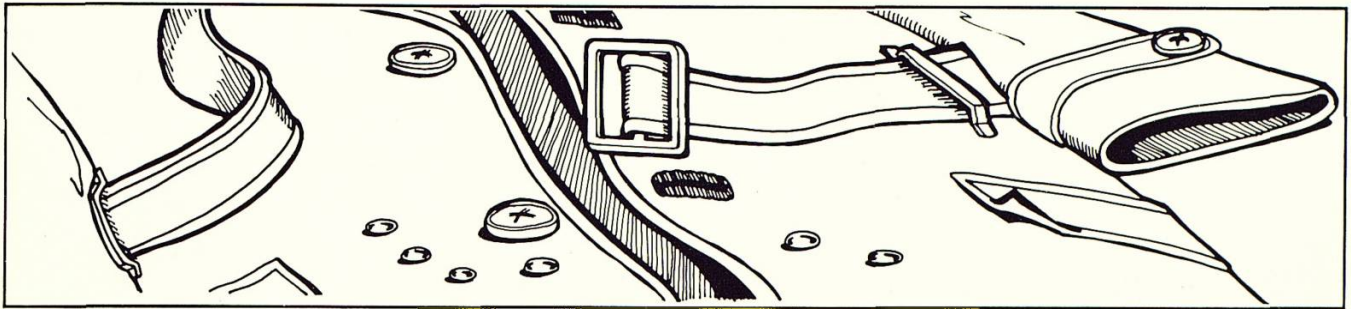

The water surface behaves as though it has a “skin”. This “pulls” the water into droplets, and stops water wetting a fabric.

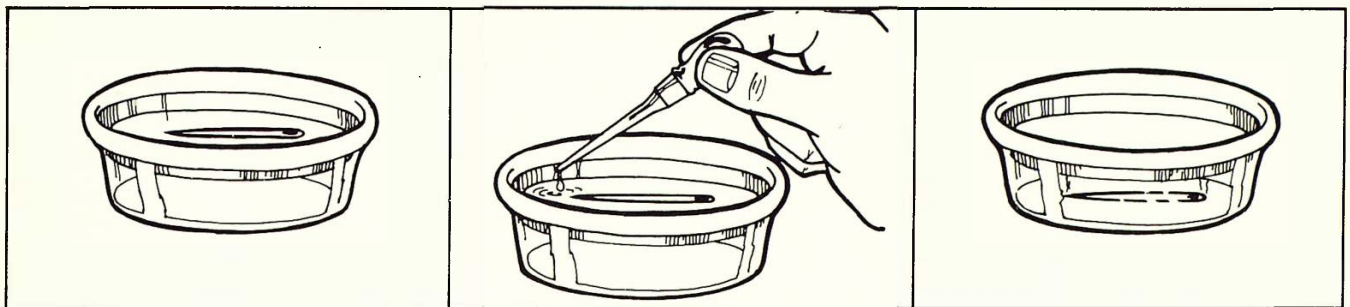

Detergent behaves as though it breaks the water’s “skin”. The needle in the left hand picture is held up by the “skin”. When detergent is added, the “skin” is broken and the needle sinks.

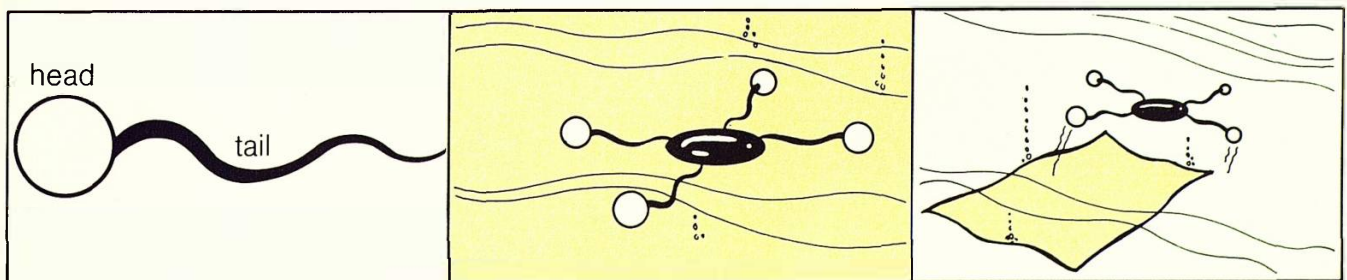

Detergent particles have two ends. The “head” likes to be in water, while the “tail” likes to be in oil.

When a fabric is washed in detergent, the detergent particles fix onto oil and dirt.

When the fabric is shaken during washing, the drop of oil or dirt comes loose. This is helped by the detergent particles.

Q10 Why are insects like the pond-skater able to walk on water?

Q12 Why is a detergent called a “wetting agent”?

Q11 Many washing machines have agitators. Explain why agitation helps get clothes clean.

10 Fabric brighteners

Investigating fabric brighteners

Apparatus

- ★ piece of black card
- ★ tweezers
- ★ laundry blue
- ★ bleach
- ★ lamp
- ★ pins
- ★ washing powder A
- ★ washing powder B
- ★ ultraviolet light box
- ★ numbered cotton samples

You are going to find out how effective fabric brighteners are.

 Do not look straight at the ultraviolet light.

Q1 Copy this table.

| Cotton sample | Treatment | Appearance in daylight | Appearance in electric light | Appearance in ultraviolet light |
|---------------|-----------|------------------------|------------------------------|---------------------------------|
| 1 | | | | |
| 2 | | | | |
| 3 | | | | |
| 4 | | | | |
| 5 | | | | |

A Pin cotton sample 1 on the black card.

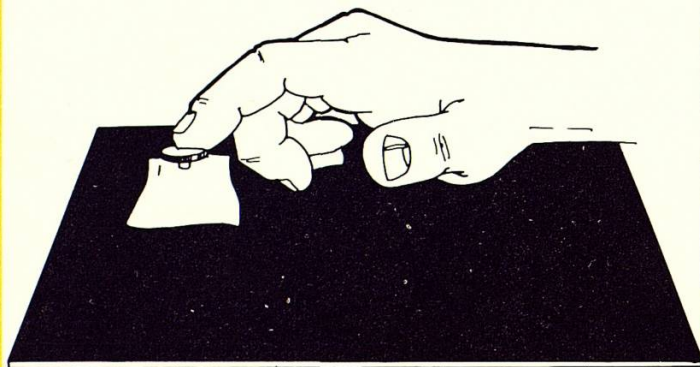

B Using tweezers, dip cotton sample 2 in laundry blue, and sample 3 in bleach.

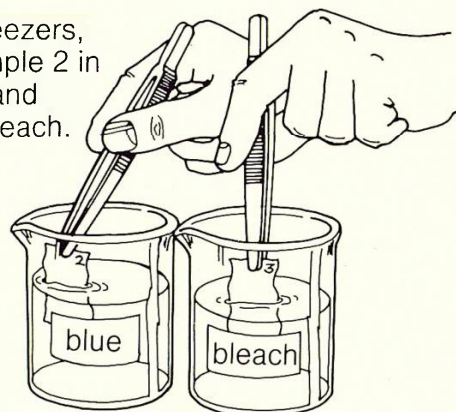

C Dip cotton sample 4 in washing powder A, and sample 5 in washing powder B.

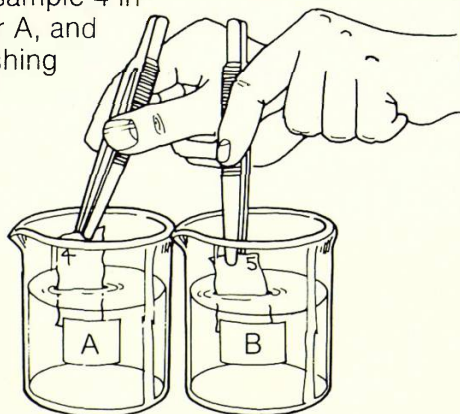

D Let all the pieces dry.

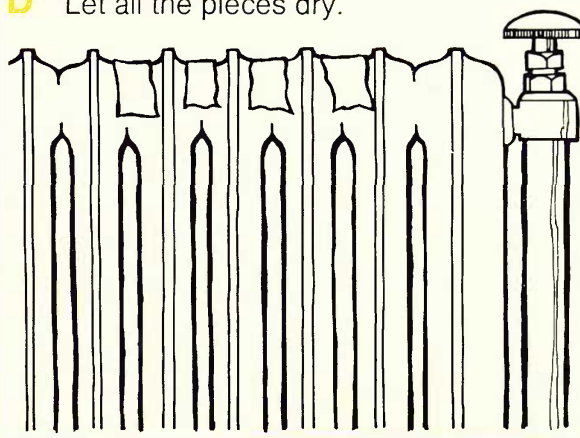

Fabric brighteners

E Pin the dry pieces to the black card.

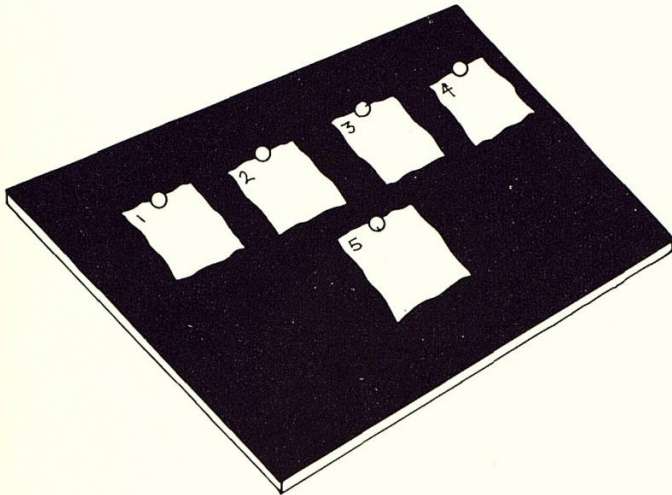

F Look at the samples in daylight. Record their whiteness in your table.



G Look at the samples in electric light. Record their whiteness in your table.



H Fit the black card into the ultraviolet light box. Switch on the lamp. Record the sample's whiteness in your table.

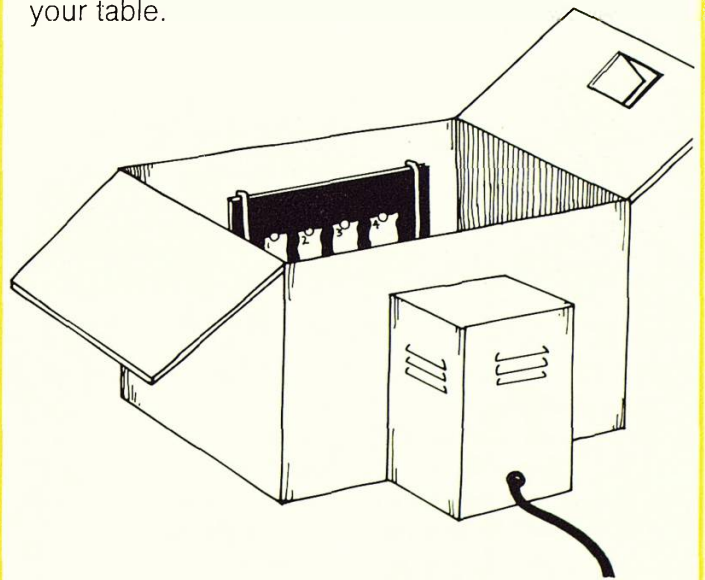

Q2 Which sample looked whitest in daylight?

Q3 Which sample looked whitest in electric light?

Q4 What did you see when you looked at the samples in ultraviolet light?

Fabric brighteners

Information: Added chemicals

Fluorescers

Some washing powders contain fluorescers. These chemicals glow purple in ultraviolet light. Daylight contains some ultraviolet light, so fabrics washed in fluorescers look blue-white.



Foam

Although foam does not help to clean clothes, it helps to sell washing powder. So modern powders have foam stabilisers added to them, to stop the foam dying away.

Other chemicals

Washing powders may also have perfume and bleach added to them. By adding chemicals, detergent companies are trying to improve their washing powders all the time.



Q5 What else do washing powders contain as well as detergent?

Q6 Look at some detergent packets and make a list of the added chemicals.

Teachers' Guide to Fibres and Fabrics

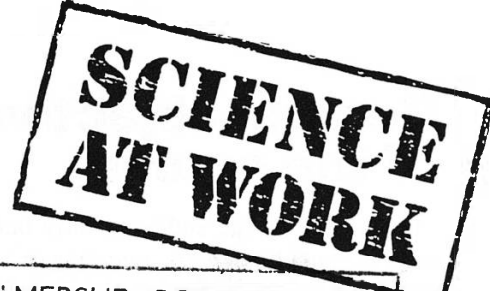

| | |
|----------------------|------------|
| BULMERSHE COLLEGE OF | |
| HIGHER EDUCATION | |
| CLASS No. | ACCESS No. |
| FT 599.07 | 124335 |

Introduction

The units

Science at Work is a series of 12 science units for 14-16 year old, less able pupils. Each unit consists of a pupils' book and a teachers' guide. Each provides a complete half-term's course of study. The units are self-contained, and can be taken in any order.

The pupils' books

The pupils' books provide information, practical investigations and questions. Pupils are thus able to work from the books at their own pace; generally, the work becomes more difficult towards the end of each book and the weakest pupils are not expected to finish every unit. The material has been checked by a language specialist, who has ensured that the reading level is as low as possible.

INVESTIGATIONS

Each investigation begins with a list of the apparatus required. The purpose is then stated, and instructions for the investigation given (in words and pictures). Finally, the pupils are asked questions which help them record their results and draw conclusions. (Throughout the books a pupil is expected to make a written response each time a 'Q' appears.)

INFORMATION

Appropriate information from the real world follows most investigations, in most cases from the world of work. Questions are also asked about these information sections.

The teachers' guides

Each unit has a teachers' guide. This contains record sheets and information for the teacher.

RECORD SHEETS

Record sheets in the form of masters are provided in each guide. These sheets will save pupils copying tables, and will help them write answers to questions as complete sentences. One record sheet is provided for each chapter of the pupils' book. Teachers may decide to give record sheets only to those pupils who have difficulty with writing; alternatively, they may be given to all pupils.

OTHER RESOURCES FOR THE TEACHER

- Each teachers' guide contains:
- course and unit objectives
 - hints on introducing and teaching the unit
 - an apparatus list (for technicians)
 - safety procedures
 - new scientific words (which pupils may have difficulty reading)
 - answers to questions in the pupils' book
 - a resource list.
- Specimen questions for a post-unit test are also included.

Examining the course

Science at Work is derived from a successful and well-proven modular scheme developed by teachers in Manchester LEA. Most of the pupils following the course in Manchester gain a CSE Mode III certificate in science. A paper giving information on CSE Mode III construction for this course is available from Addison-Wesley.

Aims of the course

1. To provide a flexible science course based on non-sequential study units. Though developed predominantly for less able pupils, the course can cater for pupils capable of CSE grade I by the addition of suitable extension work.
2. To develop pupils' thinking in scientific methodology and the approach to problem solving.
3. To give knowledge and understanding of science relevant to pupils' interests, environment, and future work and leisure needs.
4. To develop pupils' interest in science and enjoyment of science.
5. To provide a wide range of practical experiences and develop practical skills.
6. To develop the ability to work both independently and as a member of a team.

General objectives of the course

1. To develop the ability to carry out experimental procedures and written work according to instructions.
2. To develop manipulative skill in handling equipment and an awareness of safe practice.
3. To develop powers of accurate observation.
4. To develop the ability to check statements and assertions against tests of observation and experiment.
5. To develop skill in handling the interpretation of data.

6. To develop the ability to look for and make generalisations (this objective is likely to be achieved by only the ablest pupils).
7. To be able to understand and recall the factual content of the material.
8. To develop communication skills—verbal, written, and mathematical.
9. To develop the ability to apply knowledge gained.
10. To encourage pride in neatly and accurately produced work.
11. To develop awareness of the responsible use of science and technology.

Objectives of the Fibres and Fabrics unit

When they have completed this unit, the pupils will have practised the following skills:

- the use of a microscope and hand lens
- the preparation of a specimen for viewing under a microscope
- the use of a Bunsen burner
- the use of a syringe
- the timing of processes or events
- the measurement of liquid volumes
- the measurement of temperature
- the measurement of length and mass
- the drawing of microscope specimens
- the recording of observations in table form
- the use of an identification key
- the plotting of results as line graphs.

In their work on *Fibres and Fabrics* pupils will find out:

- that fabrics are made up of fibres
- that fibres can be identified by their microscopic appearance and burning characteristics
- that flameproofing retards the burning of fabrics
- that paper is made from treated and rearranged plant fibres
- that artificial or man-made fibres are made either by rearranging fibres from plant sources or by mixing chemicals
- that fibres have different strengths
- that fabrics have different wear resistances
- that fabrics vary in their insulation characteristics
- that some fabrics shrink when washed
- that detergents affect the surface tension of water and so act as wetting agents for fabrics
- that detergents clean fabrics best in agitated hot water
- that detergents contain additives that may affect fabrics in ways other than just cleaning.

Teaching the Fibres and Fabrics unit

Introducing the unit

It is suggested that the unit be introduced with an exhibition of fibres and fabrics so that the pupils will begin to appreciate the dependence of humans on such items. Pupils may bring in some items for the display.

The display could incorporate newspaper and magazine pictures with samples and information from the following:

British Wool Marketing Board (Education Dept), Oak Mills, Station Road, Clayton, Bradford, West Yorkshire

International Wool Secretariat (Education Dept), Wool House, Carlton Gardens, London SW1 5AE

The Commonwealth Institute (Information on books and films on cotton), Kensington High Street, London W8

English Sewing Ltd (Educational and Promotions Manager), 56 Oxford Street, Manchester M60 1HJ

Irish Linen Guild, 70-71 New Bond Street, London W1

Other display material can be obtained from suppliers indicated in the apparatus notes.

Teaching the unit

The pupils' book contains 10 chapters.

Each chapter has practical and information sections. There are sequential questions within each chapter: these indicate when a student has to write in a notebook. For slow readers and writers, there are record sheets to each chapter. The record sheets are copyright free and are contained within this teachers' guide (pages 7-15).

Samples of the type of questions that may be used for assessment when pupils have completed the unit are on page 16.

In the pages which follow, each chapter is discussed with reference to: apparatus per working group; new scientific words; safety and teaching hints; answers to practical questions (where necessary); resources.

General objectives of the course

1. To develop the ability to carry out experimental procedures and written work according to instructions.
2. To develop manipulative skill in handling equipment and an awareness of safe practice.
3. To develop powers of accurate observation.
4. To develop the ability to check statements and assertions against tests of observation and experiment.
5. To develop skill in handling the interpretation of data.

6. To develop the ability to look for and make generalisations (this objective is likely to be achieved by only the ablest pupils).

7. To be able to understand and recall the factual content of the material.

8. To develop communication skills—verbal, written, and mathematical.

9. To develop the ability to apply knowledge gained.

10. To encourage pride in neatly and accurately produced work.

11. To develop awareness of the responsible use of science and technology.

Objectives of the Fibres and Fabrics unit

When they have completed this unit, the pupils will have practised the following skills:

the use of a microscope and hand lens

the preparation of a specimen for viewing under a microscope

the use of a Bunsen burner

the use of a syringe

the timing of processes or events

the measurement of liquid volumes

the measurement of temperature

the measurement of length and mass

the drawing of microscope specimens

the recording of observations in table form

the use of an identification key

the plotting of results as line graphs.

In their work on *Fibres and Fabrics* pupils will find out:

that fabrics are made up of fibres

that fibres can be identified by their microscopic appearance and burning characteristics

that flameproofing retards the burning of fabrics

that paper is made from treated and rearranged plant fibres

that artificial or man-made fibres are made either by rearranging fibres from plant sources or by mixing chemicals

that fibres have different strengths

that fabrics have different wear resistances

that fabrics vary in their insulation characteristics

that some fabrics shrink when washed

that detergents affect the surface tension of water and so act as wetting agents for fabrics

that detergents clean fabrics best in agitated hot water

that detergents contain additives that may affect fabrics in ways other than just cleaning.

Teaching the Fibres and Fabrics unit

Introducing the unit

It is suggested that the unit be introduced with an exhibition of fibres and fabrics so that the pupils will begin to appreciate the dependence of humans on such items. Pupils may bring in some items for the display.

The display could incorporate newspaper and magazine pictures with samples and information from the following:

British Wool Marketing Board (Education Dept), Oak Mills, Station Road, Clayton, Bradford, West Yorkshire
International Wool Secretariat (Education Dept), Wool House, Carlton Gardens, London SW1 5AE

The Commonwealth Institute (Information on books and films on cotton), Kensington High Street, London W8

English Sewing Ltd (Educational and Promotions Manager), 56 Oxford Street, Manchester M60 1HJ

Irish Linen Guild, 70-71 New Bond Street, London W1

Other display material can be obtained from suppliers indicated in the apparatus notes.

Teaching the unit

The pupils' book contains 10 chapters.

Each chapter has practical and information sections. There are sequential questions within each chapter; these indicate when a student has to write in a notebook. For slow readers and writers, there are record sheets to each chapter. The record sheets are copyright free and are contained within this teachers' guide (pages 7-15).

Samples of the type of questions that may be used for assessment when pupils have completed the unit are on page 16.

In the pages which follow, each chapter is discussed with reference to: apparatus per working group; new scientific words; safety and teaching hints; answers to practical questions (where necessary); resources.

Detailed teaching notes

1 EXAMINING FIBRES

LOOKING AT FIBRES

(pupils' book page 1)

Apparatus: named samples of fabric: cotton, wool, linen, silk and nylon; 2 microscope slides; microscope; lamp; tweezers; beaker of water; dropper
New Words: fibre, fabric, scales

The fabric should be white or undyed. The pieces should be labelled by name with laundry marker to make the pupils' collection of samples easier and eliminate confusion. Some pupils may need help in the adjustment and focusing of the microscope.

Q2 Cotton fibres are usually twisted.

Q3 Wool is covered in scales.

Q4 Depends on the way the fibres have been spun (see specimens used).

IDENTIFYING FIBRES

(pupils' book page 2)

Apparatus: numbered samples of fabric—1 = wool, 2 = nylon; 2 microscope slides; lamp; microscope; dropper; tweezers; beaker of water
New Words: boll, lap, sliver

The fabric samples can be coloured or dyed.

Q5 Wool

Q6 Nylon

Q7 Top photograph: terylene. Bottom photograph: wool.

A selection of fabric samples and 35 mm slides showing fibres in length and cross-sectional view can be purchased from: Shirley Institute, Didsbury, Manchester M20 8RX.

2 BURNING FABRICS

IDENTIFYING FABRICS BY

BURNING (pupils' book pages 4-5)

Apparatus: numbered samples of fabrics—1 = Tricel (triacetate), 2 = polyester, 3 = nylon, 4 = Dynel (modacrylic), 5 = Acrilan, 6 = Orlon (acrylic), 7 = glass fibre, 8 = wool, 9 = silk, 10 = cotton; tongs; pair scissors; gauze; tripod; tin lid; hand lens; Bunsen burner; heatproof mat
New Words: Triacetate, polyester, modacrylic, acrylic

SAFETY: You may feel that the pupils should wear safety glasses and gloves. Each pupil or group should attempt a few of the fabrics.

Fabrics can be coloured or dyed.

Fabrics should be numbered with a laundry marker.

Q2 By examining fibres under a microscope.

MAKING FABRICS FLAME

RESISTANT (pupils' book page 6)

Apparatus: 2 sample pieces for each pupil/group of: cotton, nylon, glass fibre and wool in labelled (named) containers; flame-proofing solution in labelled beaker; Bunsen burner; heatproof mat; tongs; tweezers; stop clock; safety glasses; gloves

SAFETY: Safety glasses and gloves to be worn.

Flame-proofing solution. To make 500 cm³—43.5 g borax and 18.5 g boric acid in 500 cm³ water.

Sample pieces of fabric should be of different patterns and a poster should be displayed with samples fixed and named.

Q4 Cotton or wool (nylon will melt).

Q5 Nylon or glass fibre (they do not burn with a flame).

Information on burning and accidents in the home can be obtained from: ROSPA, Cannon House, The Priory, Queensway, Birmingham B4 6BS.

3 PAPER

LOOKING AT THE FIBRES IN PAPER (pupils' book page 8)

Apparatus: sample pieces of newspaper, paper towel, drawing paper, handkerchief tissue, strawboard and blotting paper in labelled containers; small sheet of black card; roll of clear tape; 6 microscope slides; lamp; microscope.

MAKING PAPER (pupils' book page 9)

Apparatus: wad of cotton wool; piece of felt or blanket; rolling pin; 2 sheets of metal; mortar and pestle; wire gauze; beaker of water; pencil; felt-tip pen; roll of clear tape.

New Words: pulp, recycle

4 MAKING FIBRES

MAKING NYLON (pupils' book page 11)

Apparatus: labelled beakers of solution A and solution B; 5 cm³ beaker; pair tweezers; glass rod; safety glasses; gloves

MAKING RAYON (pupils' book page 12)

Apparatus: labelled beaker of ammonia solution; reagent bottle of dilute sulphuric acid; watch glass of copper(II) carbonate; spatula; three 250 cm³ beakers; glass rod; 6 filter papers; 5 cm³ disposable syringe (no needle); safety glasses; gloves

New Word: rayon

5 THE STRENGTH OF FIBRES

TESTING THREADS TO DESTRUCTION (pupils' book pages 14-15)

Apparatus: 30 cm lengths of cotton, polyester, nylon, silk and wool threads in labelled containers; clamp and stand; weight hanger and slotted 100 g weight;

Sample pieces of paper should be named and fixed on to a display poster.
Q1–Q4 Depend on observation.

Information on paper can be obtained from: Bowater Paper Corporation, Sittingbourne, Kent ME10 3ET.

The wad of cotton wool should be large enough to cover the palm of the hand. The "paper" will be of very poor quality.

Q5 Cotton wool derived from plant material. Paper is made from another plant material, wood.

Q6 The fibres are being rearranged.

SAFETY: You may feel that the experiment should be done in a fume cupboard. Safety glasses and gloves must be worn. If the chemicals are splashed on to the skin, they must be washed off at once with soap and water.

Solution A: 5% hexamethylene diamine in water

Solution B: 5% adipyl chloride in cyclohexane

Q1 The fibre can be very long. When dry it may be "powdery".

Q2 The nylon forms at the interface of the 2 solutions: here the chemicals react together.

SAFETY: You may feel that the experiment should be done in a fume cupboard. Safety glasses must be worn. You may feel that gloves should be worn.

Ammonia solution is 1 part concentrated ammonia to 1 part water. The fumes given off from this solution are very strong.

The rayon made by this method will be of poor quality. The method is successful only if the filter paper is shredded very finely. The contents of the syringe must be expelled very slowly.

Q3 The rayon is a very light blue, thick thread.

Rayon is sometimes known as viscose.

Information on man-made fibres may be obtained from: British Man-Made Fibres Federation, Information Dept, Bridgewater House, 58 Whitworth Street, Manchester 1.

SAFETY: A bucket or bowl, half-filled with sand should be placed beneath the assembled apparatus so as to catch falling weights.

The samples should be either those of knitting/crochet materials or sewing materials. It may not be possible to get all 5 samples of the same thickness.

“G” clamp; ruler; pieces of sticky paper; split bung

New Words: Manila, Sisal, yarn, strand

6 THE WEAR OF FABRICS

INVESTIGATING WEAR

(pupils' book page 18)

Apparatus: 10 cm squares of cotton, nylon, glass fibre, wool, Tricel, linen and Acrilan in labelled containers; scissors; glue; wear wheel; stop clock

The rubber bung is slit lengthwise across the radius.

The record sheet gives only one blank table. You will need to duplicate more than one record sheet per pupil.

Q3–Q5 Man made fibres usually suspend the greatest mass and stretch most.

Instructions for a home-made wear wheel are in the “Apparatus Guide” of Nuffield Secondary Science (pub. Longman 1971) page 292.

Manufactured wear testers can be bought from suppliers such as Griffins (Wembley, Middlesex). The way the fabric is fixed to the tester depends on the type of tester used.

A display poster should have patterned samples secured and named.

Q2–Q4 The type of wear depends very much on the tension of the weaving and the type of fabric printing. Wool, linen and cotton usually have loose threads appearing. Wool and Acrilan become shiny.

Information sheets on the different uses of fibres and fabrics may be obtained from: Procter and Gamble Educational Service, PO Box 1EE, Gosforth, Newcastle-upon-Tyne NE99 1EE.

7 FABRICS AS INSULATORS

INVESTIGATING FABRICS AS

INSULATORS (pupils' book page 20)

Apparatus: 2 different, large sample pieces of fabric from the following: wool, cotton, nylon, glass fibre; beaker with polystyrene in base; tripod; Bunsen burner; gauze; heat-proof mat; stop clock; thermometer in polystyrene lid; copper vessel (calorimeter); cloth or tongs; 250 cm³ beaker; sticky tape

New Word: insulator

The width of the fabric pieces should be the same as the height of the copper vessel (calorimeter) and the length such that there will be a snug fit when the fabric is wrapped around the vessel and put in the beaker. For varied results, give different groups different sample fabrics. The size of the beaker depends on the size of the copper vessel provided. The copper vessel must be fitted with a polystyrene lid holding a 0 °–110 °C thermometer. A paint mark should be inside the copper vessel to mark the level of the water, the mark should be just below the lid.

Q3–Q4 Answers depend on the results. Wool should be the best insulator. A selection of 35 mm slides illustrating the clothing and heat insulating system used on moon landing (courtesy of Dupont Ltd) can be purchased from Shirley Institute, Didsbury, Manchester M20 8RX.

8 SHRINKAGE

WASHING FABRICS

(pupils' book page 23)

Apparatus: 7 cm squares of cotton, nylon and pre-shrunk cotton in labelled containers; ruler; tripod; Bunsen burner; gauze; heatproof mat; cloth (or tongs); thermometer; glue; glass rod; soap solution (about 100 cm³ in labelled beaker); 250 cm³ beaker; laundry marker

New Words: shrinkage, solvent

Samples with an obvious line or square pattern should be avoided.

Q2 Nylon should shrink least.

Q3 Untreated cotton should shrink most.

The soap solution is 1 part liquid detergent to 20 parts water.

Information on the care of fabrics during washing may be obtained from:

- Procter and Gamble, PO Box 1EE, Newcastle-upon-Tyne
- Home Laundering Consultative Council, 41-42 Dover Street, London W1X 4DS.

9 DETERGENTS

WHAT DETERGENTS DO

(pupils' book page 26)

Apparatus: sample pieces (2 of each) of writing paper, greaseproof paper, glass

The glass used can be clean microscope slides. All other materials can be of the same size.

and cotton fabric in labelled containers;
liquid detergent in labelled 100 cm³
beaker; 2 droppers; water in labelled
100 cm³ beaker

New Word: detergent

CLEANING FABRICS

(pupils' book pages 27-28)

Apparatus: pieces of clean and dirty
cotton fabric in labelled containers;
6 beakers (labelled 1-6); 2 glass rods;
tweezers; 1 cm³ or 5 cm³ disposable
syringe (no needle); liquid detergent in
labelled beaker; laundry marker; stop
clock; access to hot and cold tap water;
glue

New Word: agitation

10 FABRIC BRIGHTENERS

INVESTIGATING FABRIC BRIGHTENERS

(pupils' book pages 30-31)

Apparatus: 5 cm squares of white cotton,
numbered 1-5 in labelled containers;
ultraviolet lamp; cardboard box; piece of
black card; tweezers; in labelled beakers:
laundry blue, bleach, washing powder A,
washing powder B; lamp, pins

New Words: fluorescer, stabiliser

Q2 The drops on detergent-free material should be all the same shape.

Q3 Drops are "flat".

Q4 Writing paper, greaseproof paper and cotton.

White cotton fabric pieces should be soiled by rubbing in a mixture of equal parts petroleum jelly and carbon.

Q7-Q8 Yes.

Q9 Hot water, detergent and agitation.

Information on detergents can be obtained from: Unilever Education Section, Unilever House, Blackfriars, London EC4P 4BQ.

The cotton samples must be secured to the black card which must fit into a cardboard box. The card can be secured by wire. A hole must be cut in one side of the box to accommodate the UV light source. A flap in the top of the box is used for viewing the fabric samples. An "upside down" shoe box is ideal. Supply the box with the UV source attached.

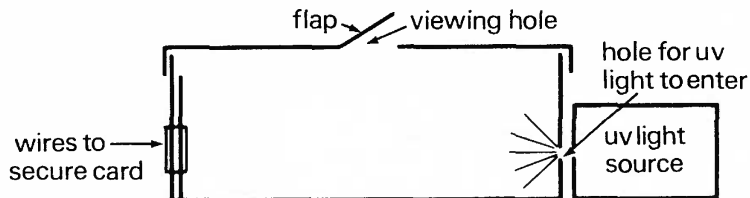

A UV light source can be purchased from Griffins (Wembley, Middlesex). Laundry blue can be "Reckitt's Liquid Blue". This and the bleach should be used undiluted.

Soap powders such as Daz, Tide and Fairy Snow are best to use. (2 spatula tips to 50 cm³ warm water.)

Q2-Q4 Depend on observations. Bleach may "yellow" the fabric. In UV light, anything with a fluorescer looks blue.

Information on laundry finishes may be obtained from: Reckitt Products, Household and Toiletries Division, Stoneferry Road, Hull.

Reference books

A. M. Collier. *A handbook of textiles*, Pergamon, 1970

J. C. Cook. *Handbook of textile fabrics*, Merrow, 1964

I. and R. Adler. *Fibres*, Dennis Dobson, 1970

B. Anderson. *Creative spinning, weaving and plant dyeing*, Angus and Robertson, 1971

J. Bainbridge. *Man made*, Evans, 1973

S. E. Ellacott. *Spinning and weaving*, Methuen, 1962

L. M. Gawthrope. *Fabrics and laundry work*, Hulton, 1971

B. Gurbutt. *Paper*, Watts, 1976

S. Hood. *Adventures in weaving*, Wolfe, 1970

G. M. Lambert. *Your book of chemistry*, Faber, 1968

A. M. McFarland. *Let's learn about what we wear*, Johnston & Bacon, 1964

O. Robinson. *Making paper*, OUP, 1969

P. Shillinglaw. *Introducing weaving*, Batsford, 1972

R. W. Thomas. *The household chemicals*, Wheaton, 1975

M. Wilkerson. *Clothes*, Batsford, 1970

Junior Reference Library. *Textiles*, Macdonald, 1969

1 Examining fibres

LOOKING AT FIBRES (page 1)

Q1

| Name of fabric | Drawing of fibre |
|----------------|------------------|
| Cotton | |
| Wool | |
| Linen | |
| Silk | |
| Nylon | |

Q2 The twisted fibres were

Q3 The fibres covered in scales were

Q4 The fibres made of smaller fibres were

IDENTIFYING FIBRES (page 2)

Q5 Fabric 1 is

Q6 Fabric 2 is

Q7 Top photo: The fabric is

Bottom photo: The fabric is

INFORMATION: COTTON (page 3)

Q8 A cotton boll is

Q9 Cotton is combed after it has been made into slivers because

.....

Q10 Cotton is grown in, and

Q11 Some of my clothes made of cotton are

.....

2 Burning fabrics

IDENTIFYING FABRICS BY BURNING (page 4)

Q1

| Fabric name | Did it melt on the lid? | Did it burn—fast, slowly or not at all? | Was the burned fabric light, dark or black? | Did the burned fabric bend or snap? | Fabric number |
|-------------|-------------------------|---|---|-------------------------------------|---------------|
| | | | | | 1 |
| | | | | | 2 |
| | | | | | 3 |
| | | | | | 4 |
| | | | | | 5 |
| | | | | | 6 |
| | | | | | 7 |
| | | | | | 8 |
| | | | | | 9 |
| | | | | | 10 |

INFORMATION: FABRIC IDENTIFICATION CHART (page 5)

Q2 You can tell the difference between wool and silk by

MAKING FABRICS FLAME RESISTANT (page 6)

Q3

| Name of fabric | Time for unsoaked fabric to start burning (seconds) | Time for flame proofed fabric to start burning (seconds) |
|----------------|---|--|
| | | |
| | | |
| | | |
| | | |

Q4 The unsoaked fabric which took the shortest time to start burning was

Q5 The unsoaked fabric which took the longest time to start burning was

Q6 Flame proofer *did/did not* stop any fabric burning.

INFORMATION: FLAME RESISTANT CLOTHING (page 7)

Q7 Clothes get hot when

Q8 You can find out if a nightdress is flame resistant by

Q9 If a person's clothes catch fire you should

3 Paper

LOOKING AT THE FIBRES IN PAPER (page 8)

- Q1 The paper with the longest fibres is
- Q2 The paper with the shortest fibres is
- Q3 The paper with the thinnest fibres is
- Q4 The paper with the thickest fibres is

MAKING PAPER (page 9)

- Q5 Cotton wool is used to make paper because
- Q6 When pulped in a mortar the fibres in cotton wool are

Q7

Stick your sample here

My sample of paper.

INFORMATION: PAPER (page 10)

- Q8 All the materials used to make paper are
- Q9 Wood pulp is bleached to
- Q10 Recycling means
- Q11 It is important to recycle paper because

4 Making fibres

MAKING NYLON (page 11)

- Q1 The nylon fibre is
- Q2 In the beaker nylon forms This is because

MAKING RAYON (page 12)

- Q3 The rayon is

INFORMATION: MAN-MADE FIBRES (page 13)

- Q4 is a natural fibre.
- Q5 The first man-made fibre was
- Q6 Nylon was first produced in
- Q7 The properties of nylon are
- Q8 Filter paper was used in making rayon to

5 The strength of fibres

TESTING THREAD TO DESTRUCTION (page 14)

Q1

| Name of thread | Mass added when thread snapped ... |
|--------------------------------|--|
| Mass (weight) added (grams) | Distance between markers (cm) |
| | |
| | |
| | |
| | |
| | |
| | |
| | |
| | |
| | |
| | |
| | |
| | |
| | |
| | |
| | |

Q2

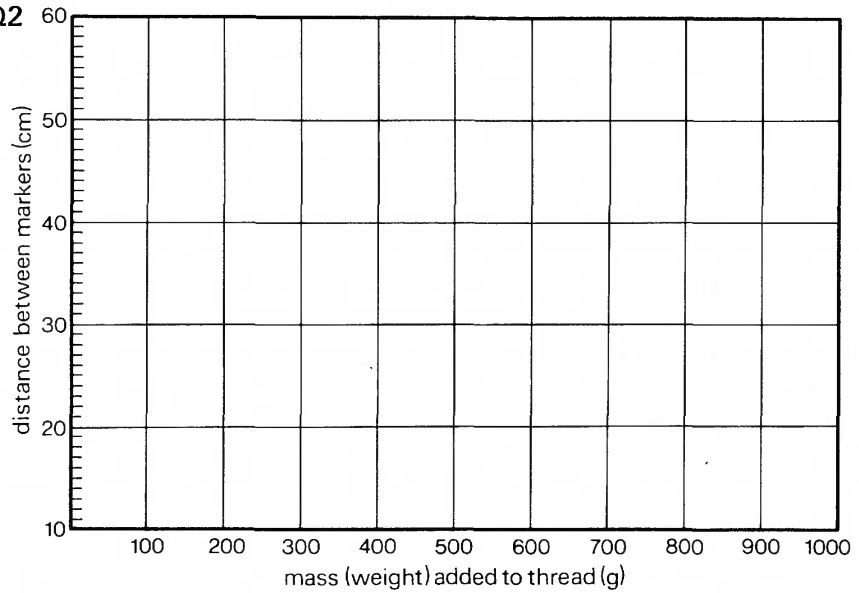

- Q3** The thread which held the heaviest mass (weight) was
- Q4** The weakest thread was
- Q5** The thread which stretched most was

MAKING ROPES (page 17)

- Q6** The natural fibres used to make rope are
- Q7** The order of size is (smallest first)
- Q8** Yarns are twisted one way and strands the other so that
- Q9** The advantages of a man-made fibre rope are
- Q10** Man-made fibre ropes are damaged by

6 The wear of fabrics

INVESTIGATING WEAR (page 18)

Q1

| Name of fabric | No. of fabric | Piece of unworn fabric | Piece of worn fabric |
|----------------|---------------|------------------------|----------------------|
| | 1 | | |
| | 2 | | |
| | 3 | | |
| | 4 | | |
| | 5 | | |
| | 6 | | |
| | 7 | | |

Q2 The fabrics in which holes, tears or loose threads appeared were

.....

Q3 The fabrics that became shiny were

Q4 The fabrics that faded were

INFORMATION: STANDING UP TO WEAR (page 19)

Q5 Wear resistance means

Q6 Two ways of making fabric stronger are

.....

Q7 To make the knees of trousers stand up to wear you could

.....

7 Fabrics as insulators

INVESTIGATING FABRICS AS INSULATORS (page 20)

Q1

| Time (minutes) | 0 | 2 | 4 | 6 | 8 | 10 | 12 | 14 | 16 |
|--|---|---|---|---|---|----|----|----|----|
| Water temperature (°C), vessel covered in fabric 1 | | | | | | | | | |
| Water temperature (°C), vessel covered in fabric 2 | | | | | | | | | |
| Water temperature (°C), vessel surrounded by air | | | | | | | | | |

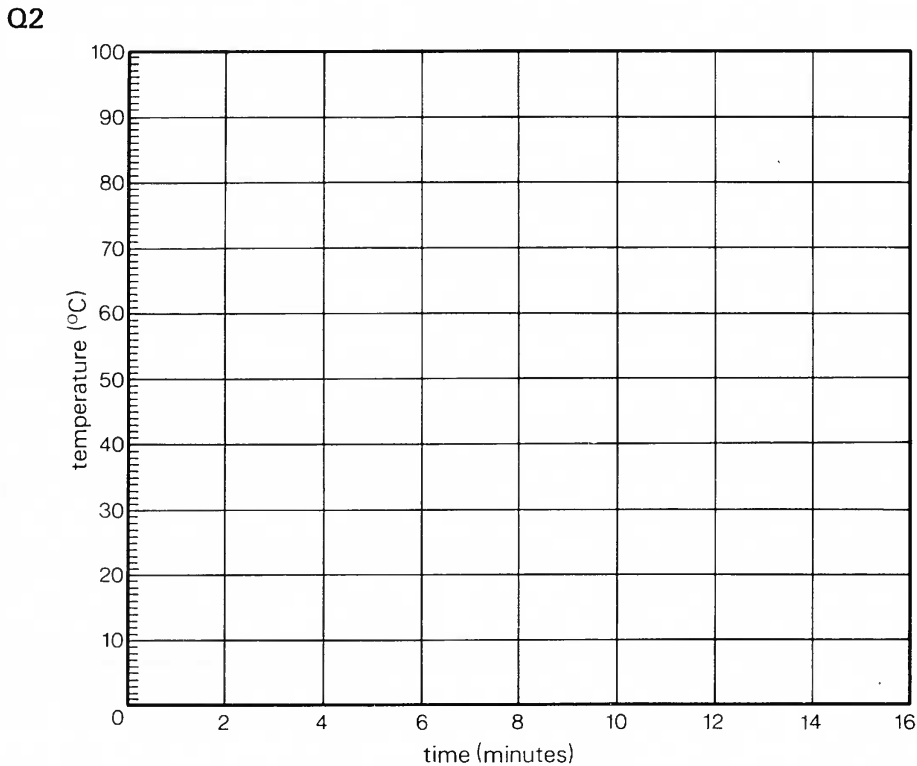

- Q3 Look at your graph.
- (a) In 16 minutes the temperature of the water surrounded by fabric 1 dropped °C.
 - (b) In 16 minutes the temperature of the water surrounded by fabric 2 dropped °C.
 - (c) In 16 minutes the temperature of the water surrounded by air dropped °C.

Q4 The best insulator was

INFORMATION: KEEPING WARM OR COOL (page 22)

- Q5 The normal temperature of the human body is
- Q6 A padded anorak helps to keep a climber warm by
- Q7 An insulator is
- Q8 Foam insulates a house by

8 Shrinkage

WASHING FABRICS (page 23)

Q1 The sizes of the squares after washing were:

cotton = , nylon = , pre-shrunk cotton =

Q2 The material which shrunk least was

Q3 The material which shrunk most was

INFORMATION: CARE OF FABRICS (page 25)

Q4 A care label is

Q5 HLCC stands for

Q6 (a)



means

(b)



means

(c)



means

Q7 The 40° in the symbol means

Q8



means



means

Q9 A solvent is

9 Detergents

WHAT DETERGENTS DO (page 26)

Q1

| Name of material | Shape of water drop on material | Shape of water drop on material + detergent |
|------------------|---------------------------------|---|
| | | |
| | | |
| | | |
| | | |

Q2 All the drops *are/are not* the same.

Q3 The detergent *did/did not* make a difference to the drop shapes.

Q4 materials were wetted by the water drop going into the material.

CLEANING FABRICS (page 27)

Q5

| Beaker number | Cold water | Hot water | Detergent | Stir | Piece of the fabric |
|---------------|------------|-----------|-----------|------|---------------------|
| 1 | ✓ | | | | |
| 2 | | ✓ | | | |
| 3 | ✓ | | ✓ | | |
| 4 | | ✓ | ✓ | | |
| 5 | ✓ | | ✓ | ✓ | |
| 6 | | ✓ | ✓ | ✓ | |

Q6 The 6 pieces of dry washing *were/were not* as clean as the one clean piece.

Q7 Stirring *does/does not* help clean the fabric.

Q8 Heat *does/does not* help clean the fabric.

Q9 The best conditions for washing fabric are

.....

9 Detergents (continued)

INFORMATION: HOW DETERGENTS WORK (page 29)

Q10 Insects like pondskaters can walk on water because

.....

Q11 A detergent is called a "wetting agent" because

.....

Q12 Agitation helps get clothes clean because

.....

10 Fabric brighteners

INVESTIGATING FABRIC BRIGHTENERS (page 30)

Q1

| Cotton sample | Treatment | Appearance in daylight | Appearance in electric light | Appearance in ultraviolet light |
|---------------|-----------|------------------------|------------------------------|---------------------------------|
| 1 | | | | |
| 2 | | | | |
| 3 | | | | |
| 4 | | | | |
| 5 | | | | |

Q2 The sample that looked whitest in daylight was number

Q3 The sample that looked whitest in electric light was number

Q4 When I looked at the samples under ultraviolet light I saw

.....

INFORMATION: ADDED CHEMICALS (page 32)

Q5 As well as detergent, washing powders contain

Q6 Some of the chemicals added to detergents are

.....

.....

Specimen post-unit questions

- Which of the fibres or fabrics in the list is man-made? (Tick the right answer.)
a) cotton b) wool c) nylon d) linen
- Which of the fibres or fabrics in the list comes from an animal? (Tick the right answer.)
a) cotton b) paper c) sisal rope d) wool
- Which of the symbols in the list means a fabric should be ironed with a cool iron? (Tick the right answer.)

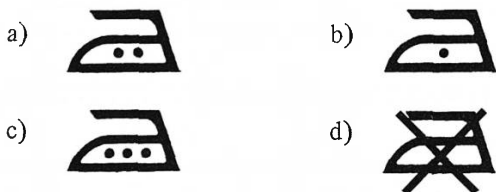

- What is a fluorescer? (Tick the right answer.)
a) it makes water flow
b) it makes a lot of froth in water
c) it makes fabric reflect ultraviolet light
d) it contains fluorine
- Four fabric pieces were held in a flame. The time taken for each fabric to start burning was noted.

| Fabric | Time (in seconds) to start burning |
|----------|------------------------------------|
| Linen | 4 |
| Cotton | 2 |
| Nylon | 3 |
| Asbestos | never started |

Now write the answers to the questions about this table.

- Which fabric caught fire quickest?
- Which fabric caught fire slowest?
- Which fabric could you use to make a fire-proof overall?

- Read the following paragraph carefully.

Wool is a natural fibre. Wool must be washed with care. Experts say that wool must be washed with soapless detergent in hard water areas like Lancashire. Scum is formed by soap in hard water. Scum clings to the wool fibres and may not be removed by rinsing. If a woollen garment is not washed properly, it may shrink. When it shrinks, wool may felt. This makes the garment become stiff and smaller. Felting happens like this. Wool fibres have an outer layer of tiny rough scales. These scales can be seen under a microscope. When they are woven into a fabric, wool fibres move against each other. If a fabric felts, the scales on the fibre tangle.

Now answer these questions.

- Name one natural fibre other than wool.
- Name one part of England where water is hard

- Why must soap not be used to wash woollens in hard water areas?
- What would happen to a woollen jumper if it felt?
- How could you see the scales on wool fibres?

- A piece of cotton thread was fixed into a stopper. The stopper was fixed as shown in the diagram. Weights were added to the weight hanger. Each time a weight was added, the distance between the markers was noted. The same experiment was done with nylon. The results were plotted as line graphs.

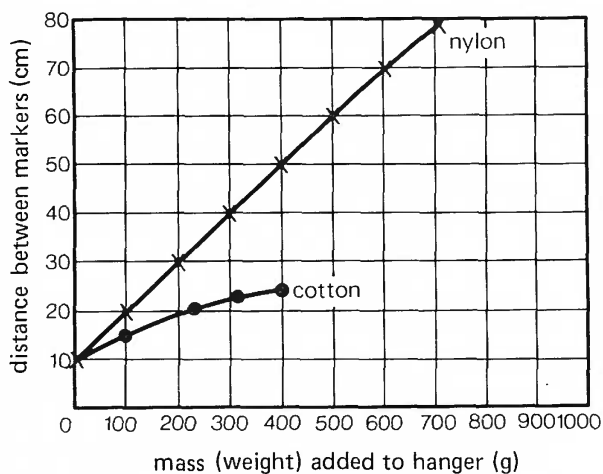
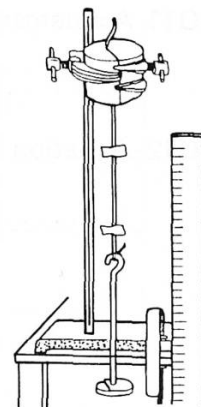

Now answer these questions about the experiment and graph.

- What was the distance between the markers on the nylon thread when the mass (weight) on the hanger was 200 g?
- When the distance between the markers was 70 cm, how much mass (weight) had been added to the nylon thread?
- Why do the "lines" for nylon and cotton on the graph both start at 10 on the vertical (upright) axis?
- Which thread stretched most?
- Why do you think there are no values for cotton after the addition of 400 g to the weight hanger?

Acknowledgements

The publishers wish to thank the following for kind permission to reproduce photographs:-

Courtaulds Limited (cover; fibres, page 2; machine forming lap and weaving, page 3; production of rayon and nylon, page 13); Shirley Institute (cotton flowers and boll, page 3); Bowater Paper Limited (waste paper, page 10); International Wool Secretariat (person dressed in wool, page 13); Dunlop Sports Company Limited (nylon products, page 13); John Mortlock (Cutty Sark, page 16); John Woodhouse (rock climber, page 17); Health Education Council/Fotocall (person running, page 22); V. Yakovlev (APN) (eskimo, page 22); Blacks of Greenock (anorak, page 22); E.T. Skinner and Company Limited (wetsuit, page 22); Megafoam Limited (cavity wall insulation, page 22); Lever Brothers Limited (Lux advertisement, page 32).

SCIENCE AT WORK

Project Director

John Taylor

The books in this series are:

Fibres and Fabrics

Electronics

Forensic Science

Photography

Gears and Gearing

Cosmetics

Body Maintenance

Pollution

Building Science

Food and Microbes

Domestic Electricity

Dyes and Dyeing

