

The Gas Supply Problem

Contents: Information and problem-solving exercise concerning the distribution and use of natural gas.

Time: 1 to 2 periods.

Intended use: GCSE Chemistry, Physics and Integrated Science. Links with work on fuels, natural gas and pressure.

Aims:

- To complement prior work on gaseous fuels and their uses
- To show in outline how natural gas is produced, distributed and used
- To provide an opportunity to practise problem-solving skills.

Requirements: Students' worksheets No. 702

Suggested use

Students should read the introductory material before tackling the problem-solving task. The task itself will probably take 20 to 30 minutes, and is best done by students working in groups of 2 or 3.

It would be useful to follow up the task with a discussion of the different designs. How do they compare? What problem might arise with each? Which is the best design?

General notes on the task

It is not expected that students will arrive at the exact 'answer' to the gas supply problem as used by British Gas (this 'answer' is given in Figure 8 of the students' materials, for teachers to duplicate and distribute if they wish). But good solutions to the problem should incorporate the following features:

- (a) A high-pressure long-distance transmission network, with compressors every 65km or so (see note (1) below)
- (b) A low-pressure distribution system for houses, and intermediate pressure distribution to factories (see note (2) below)
- (c) Some kind of storage facility to cope with variations in demand (see note (3) below)
- (d) Some kind of pressure-reduction stations between the different parts of the system (see note (4) below).

The information given in the students' materials is limited and simplified. The notes which follow provide further information for the teacher, which can be supplied to students as the teacher considers appropriate.

Further notes

- 1 The map below shows the National Gas Transmission System, the high-pressure, long-distance network distributing gas around the country.

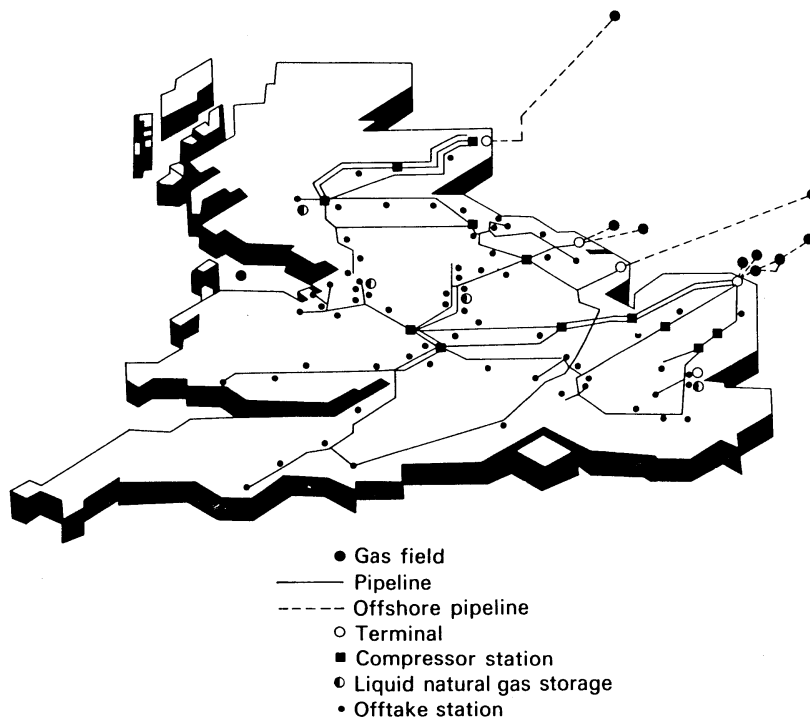

The compressors are driven by gas turbines resembling jet engines, fuelled by the gas itself. Their noise is attenuated by acoustic insulation of the station.

- 2 Many urban areas have a 'ring main' system, with a loop, working at intermediate pressure and fed by the National Transmission System, running around the area. Low-pressure domestic distribution networks are fed from this ring through pressure-reducing regulators. Industrial users are fed direct from the intermediate pressure ring main. Flow within the ring can be in either direction, so interruption at a particular part of the ring will not necessarily result in general failure.
- 3 Variation in demand is considerable, according to the time of year (Table 1), the day of the week (Table 2) and the time of day.

Table 1 Variation in monthly demand for gas, April 1984—March 1985/ 10^9 cubic metres

Month	Apr	May	Jun	Jul	Aug	Sep	Oct	Nov	Dec	Jan	Feb	Mar
Demand 10^9 m ³	4.1	3.4	2.3	2.0	1.9	2.8	3.9	5.0	5.9	7.2	6.2	6.3

Table 2 Variation in daily demand for gas, August 4th—13th 1984 and February 1st—10th 1985/10⁹ cubic metres

Day	Average outdoor temperature/ °C	Gas demand/10 ⁹ m ³
Fri Aug 4th 1984	14	0.058
Sat Aug 5th 1984	14	0.065
Sun Aug 6th 1984	15	0.071
Mon Aug 7th 1984	14	0.073
Tues Aug 8th 1984	16	0.071
Wed Aug 9th 1984	17	0.069
Thurs Aug 10th 1984	16	0.063
Fri Aug 11th 1984	16	0.059
Sat Aug 12th 1984	17	0.061
Sun Aug 13th 1984	17	0.069
Fri Feb 1st 1985	10	0.19
Sat Feb 2nd 1985	8	0.16
Sun Feb 3rd 1985	8	0.17
Mon Feb 4th 1985	7	0.19
Tues Feb 5th 1985	6	0.20
Wed Feb 6th 1985	6	0.20
Thurs Feb 7th 1985	3	0.23
Fri Feb 8th 1985	1	0.24
Sat Feb 9th 1985	-2	0.24
Sun Feb 10th 1985	-3	0.25

British Gas buys gas from North Sea producers under contract. According to these contracts British Gas is able to vary the amount of gas it takes, but only within certain upper and lower limits. In times of high demand, too little gas will be coming ashore; in times of low demand, there will be too much. To overcome these problems, bulk storage of gas is essential.

Several kinds of storage are used:

- (a) In large tanks
- (b) In underground salt cavities
- (c) Storage as liquefied gas at low temperatures
- (d) In depleted gas fields
- (e) By 'line pack' — pressurizing parts of the transmission system near areas of high demand to above normal pressure, thus 'packing' more gas into the transmission system.

The first three of these storage methods are indicated in the 'answer' on Figure 8.

Some kind of low-pressure local storage is also needed, to cope with short-term fluctuations in demand, since it takes several hours for gas to travel from the East Coast terminals to the various parts of the country. Thus, gas-holders can still be seen in some urban areas, though they are far less common than in the days when gas was made from coal.

- 4 Pressure-reduction systems work on the general principle of passing the gas through a constriction. This creates two problems: considerable noise, and icing due to the rapid expansion of the gas. The first is overcome by sound insulation at the pressure reduction stations; the second by suitable heat-transfer measures. Both points can be illustrated by blowing up a balloon, then allowing the air to escape through the neck.

Further activities

If time and interest permit, students could tackle further questions relating to gas supply, for example:

- 1 By the end of this century, supplies of gas from the North Sea reserves will begin to fall below demand. What will Britain do for gas supplies then? (*Gas will be produced from coal, since supplies of coal are sufficient to long outlast those of gas and oil.*)

- 2 Try to explain the trends in gas demand at different times of year shown in Table 1.
- 3 Try to explain the trends in gas demand at different times of the week shown in Table 2.
- 4 Compare the advantages and disadvantages of (a) polythene pipes, (b) steel pipes for (i) low-pressure local networks, (ii) long-distance, high-pressure pipelines.

Further resources

Two useful sources of information concerning various aspects of the gas industry are:

- 1 *The Gass Book*, a joint publication of ASE and British Gas, available from ASE, College Lane, Hatfield, Herts AL10 9AA.
- 2 *Science in Society Book O: Engineering 3*, published by ASE/Heinemann.

The British Gas Educational Service has a wide range of printed and audio-visual materials available free of charge or at subsidized prices. Their catalogue can be obtained from: British Gas Educational Service, PO Box 46, Hounslow, Middlesex TW4 6NF. The catalogue also contains details concerning visits to gas industry establishments, and of visiting lecturers.

The British Gas Film Library includes a range of films and videos on free loan. The catalogue can be obtained from: British Gas Film Library, Park Hall Road Trading Estate, London SE21 8EL.

Acknowledgements The data in Tables 1 and 2 in the Teachers' Notes is taken from *UK Times British Gas Worksheet 2*; Figures 1 and 6 supplied by British Gas; Figures 2, 3, 4, 7 and 8 and the map in the Teachers' Notes are reproduced by permission from *Science in Society, Book O: Engineering 3* (ASE/Heinemann); Figure 5 supplied by Norwest Holst Ltd.

THE GAS SUPPLY PROBLEM

Natural gas occurs in large amounts below the North Sea. It is the job of British Gas to bring it ashore and distribute it to the fifteen million customers who use gas. This is not quite as simple as it sounds, as you will find out when you try the Gas Supply Problem later in this unit. First, read the following background information about gas.

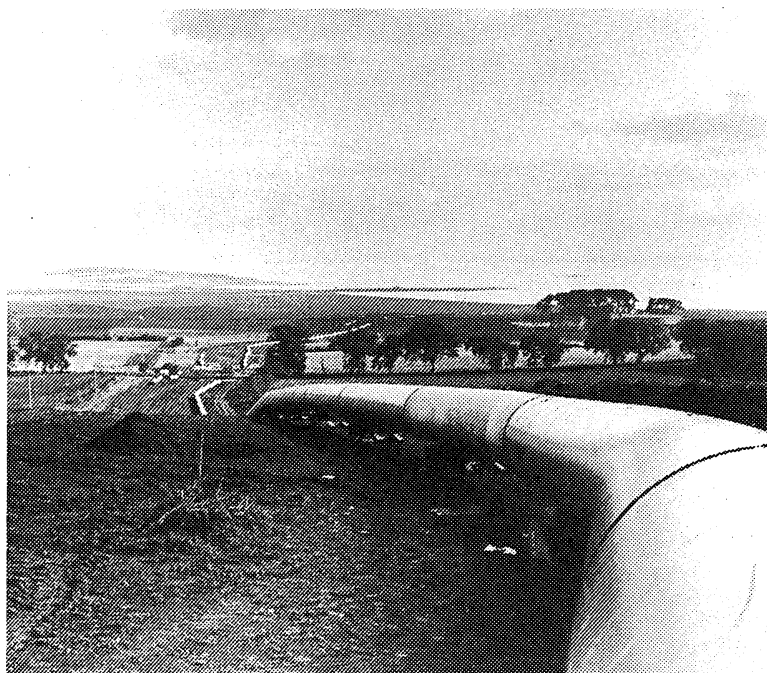
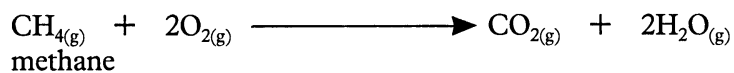

Figure 1 Part of the metre diameter pipeline which carries gas from the North Sea down the east coast of Britain. Here the pipeline is strung out before being buried.

Who uses gas?

Natural gas is almost pure methane, CH_4 . It is an excellent fuel. It burns with a hot, easily controllable flame, forming carbon dioxide and water.



Provided the burner is properly adjusted, very few pollutants are formed when gas burns. Natural gas has no smell — in fact, a small amount of a smelly substance has to be added to it to help people detect leaks. It is important to prevent leaks, because gas can form explosive mixtures in air.

As Figure 2 on the next page shows, homes are the biggest users of natural gas. But industry uses a lot of gas too, especially where a clean, pure fuel is needed. Natural gas can also be used to make organic chemicals. Figures 3 and 4 on the next page give more details of how gas is used in homes and in industry.

How is gas supplied?

Customers expect the gas supply to be completely reliable, and never fail. To make sure of this, a carefully planned and designed supply system is needed.

Gas is supplied in pipes. There are 210 000 km of gas pipes in Britain — enough to reach more than half way to the moon. The more gas there is to carry, the bigger the pipes have to be. The largest pipes are over a metre in diameter and are made of steel. These carry gas long distances around the country. This gas is at high pressure — over 70 atmospheres.

The smallest pipes are the local service pipes which carry gas to individual houses. They are about 10 cm diameter. Some of these are quite old and may be a little leaky. To cut down leaks, the gas in these local pipes has to be at low pressure. The pressure is just over one atmosphere — about the same as the pressure inside a party balloon. These local pipes used to be made of cast-iron or steel, but this is being replaced by polythene. Polythene is strong and flexible and does not corrode. The pipes can be joined together by melting the plastic.



Figure 5 Local service pipes — under the roadway on Westminster Bridge

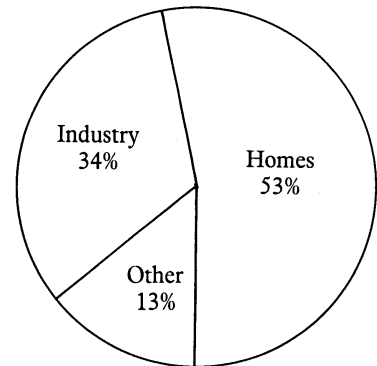

Figure 2 Where natural gas is used

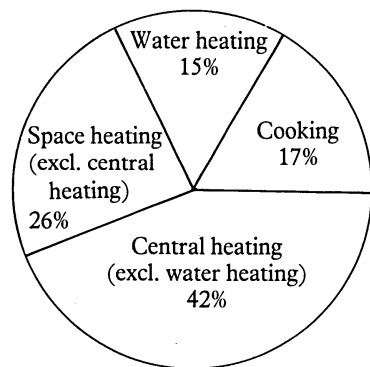

Figure 3 Uses of natural gas in the home

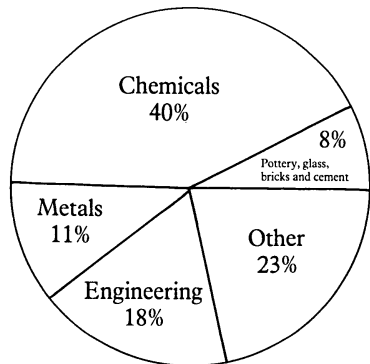

Figure 4 Uses of natural gas in industry

The corrosion problem

Gas pipelines are buried underground. The soil is usually damp and may also be acid or alkaline. With polythene pipes this is no problem, but the large high pressure pipes made of steel tend to corrode quickly under these conditions. The pipes have to be protected by special waterproof wrappings or coatings.

Checking for leaks

Small leaks in the local, low-pressure network of pipes are wasteful, but not particularly dangerous. They can be detected by sensitive 'gas sniffing' equipment, and the leaking pipe can then be dug up and repaired. But a leak in one of the large, high-pressure pipes would be very wasteful and dangerous. These pipes have to be checked regularly for corrosion, so that faults can be spotted before the pipe starts leaking.

But the pipes are buried underground, which makes checking difficult. To get over this problem, a machine called an 'intelligent pig' is used (Figure 6).

It travels *inside* the pipe, pushed along by the pressure of the gas. Magnetic and electronic equipment on board checks the pipe walls for faults as the machine moves along. Once a fault has been located, a hole is dug and the pipeline is repaired.

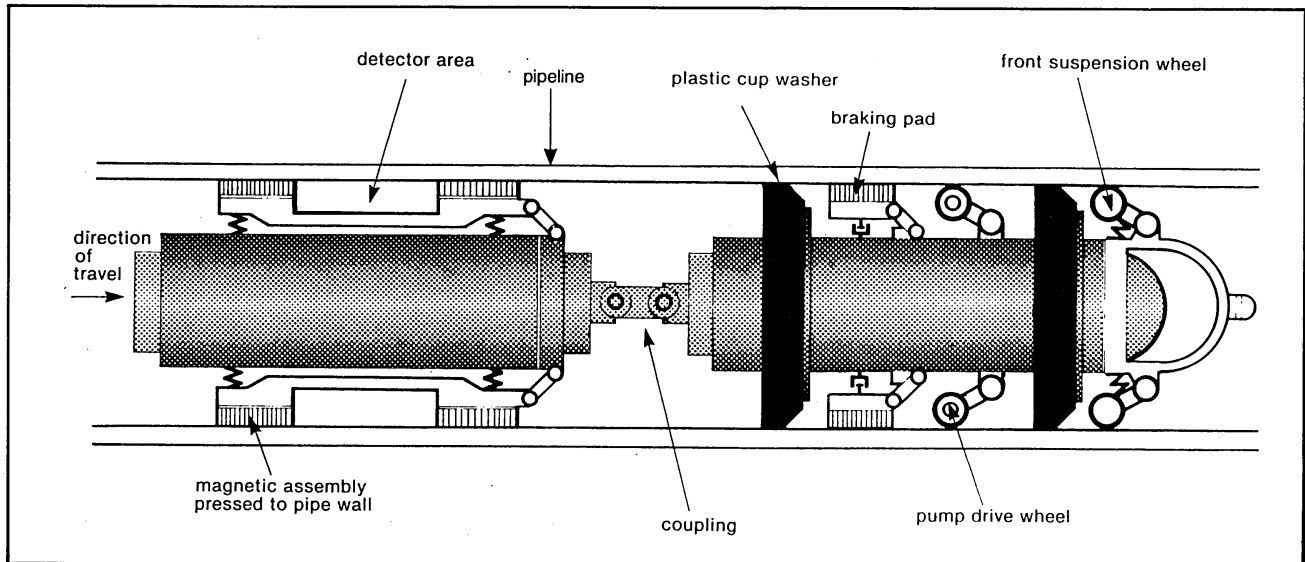

Figure 6 The 'intelligent pig'

The Gas Supply Problem — your task

North Sea Gas comes ashore at a high pressure (70 atmospheres). It is distributed to users in pipes.

Your problem is to design a distribution system. Your design must bear in mind all the following points:

- Homes use gas at low pressure (just over one atmosphere).
- Factories use gas at medium pressure.
- Gas forms explosive mixtures with air.
- More gas is needed in winter than in summer.
- The demand for gas varies according to the time of day.
- Gas needs to be kept at high pressure for long-distance travel. However, because of friction with the walls of the pipe, the pressure of gas falls the further it flows. Compressor stations are needed every 65 km to keep the gas at high enough pressure.
- When gas is carried in pipes, the more gas that is carried, the wider the pipe must be.
- Your design should be unobtrusive wherever possible.

What you do

This task is best tackled working in groups of 2 or 3.

Look at Figure 7. On the blank part of the diagram, draw in *pencil* your design for the system to distribute gas between start and finish. Remember — your design must meet *all* the points mentioned above.

When you are happy with your pencilled design, go over it in ink, and perhaps colour it.

Figure 7 The Gas Supply Problem

START
The gas comes ashore at 70 atmospheres pressure

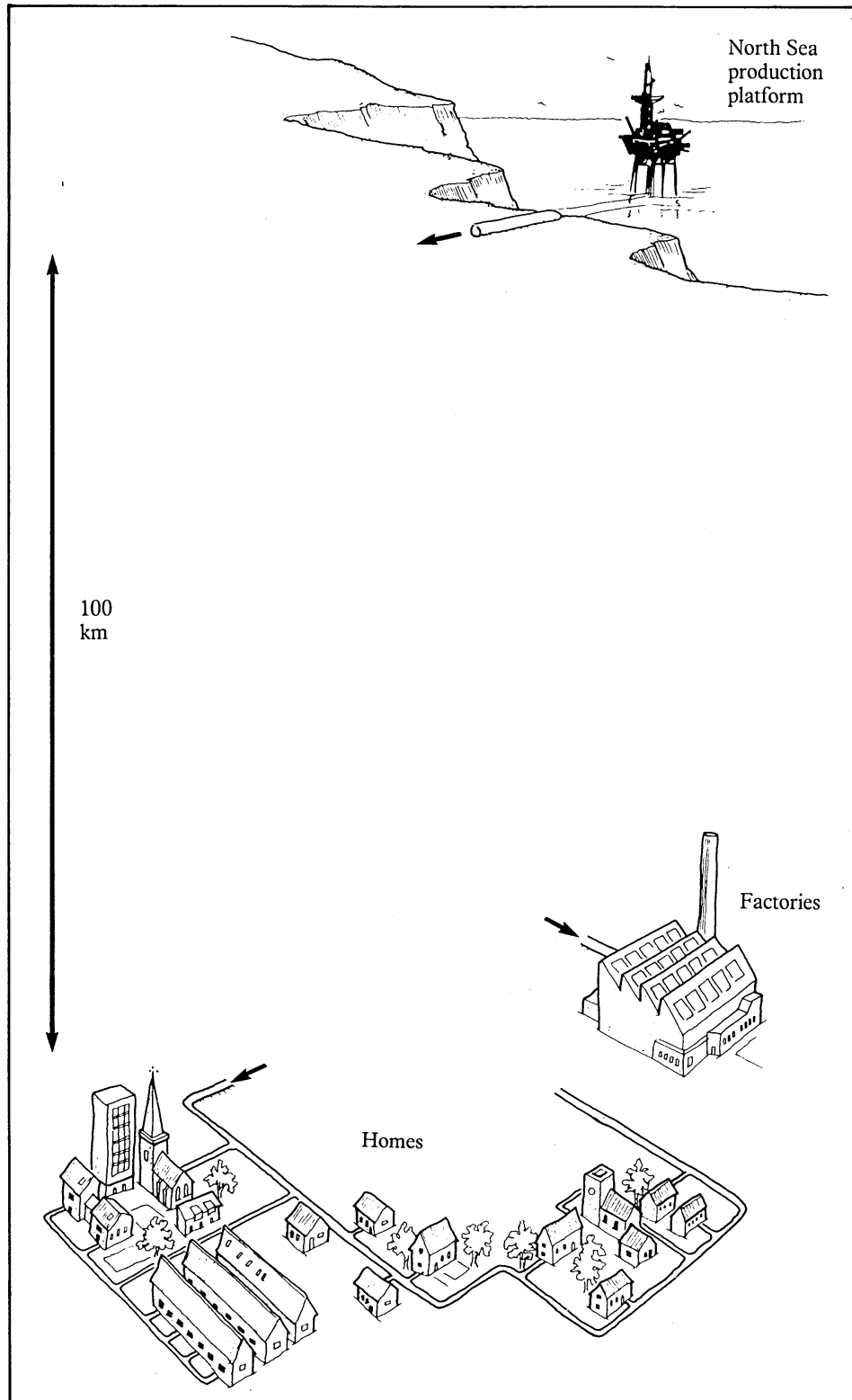

FINISH
The gas is supplied to homes and factories

WHAT GOES IN BETWEEN?

Figure 8 The Gas Supply Problem — British Gas's answer

